

FACTORY AUTOMATION

- INDUCTIVE ◀
- CAPACITIVE ◀
- PHOTOELECTRIC ◀
- OPTICAL FIBERS ◀
- ULTRASONIC ◀
- MAGNETIC ◀
- OTHER PRODUCTS ◀



Tubular Inductive Sensors

Gas and Combustible Dust Atmosphere Certified



Ø6,5 Ø8,0 and M8 NAMUR Line

Ø 6,5 mm or
Ø 8 mm

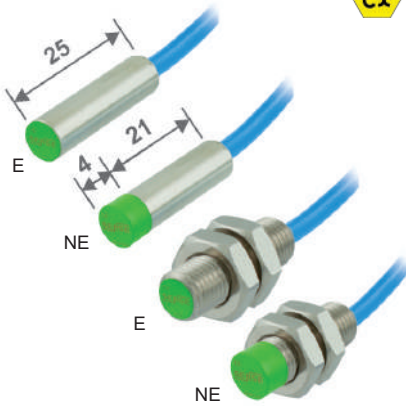

Distance	CE	Feeding	Output	Mount.	Connection		Tube Length	Code		
1 mm	NAMUR	7 to 12Vdc	NC	E	Cable	2 wires	25 mm smooth	PS1-6,5-25-N-Ex		
			NC/Illuminated					PS1-6,5-25-N-L-Ex		
			NC					PS1-8-25-N-Ex		
			NC/Illuminated					PS1-8GM25-N-Ex		
1,5 mm			25 mm threaded	PS1-8GI25-N-L-Ex						
				PS1,5-8GM45-N-Ex						
2 mm			NE		NC	E	Cable	2 wires	45 mm threaded	PS2-6,5-25-N-Ex
					NC/Illuminated					PS2-6,5-25-N-L-Ex
	NC	PS2-8-25-N-Ex								
	NC/Illuminated	PS2-8GM25-N-Ex								
25 mm smooth	PS2-8GI25-N-L-Ex									
		PS2-8GI25-N-L-Ex								
25 mm threaded	PS2-8GI25-N-L-Ex									

M12 NAMUR Line

Ø 12 mm

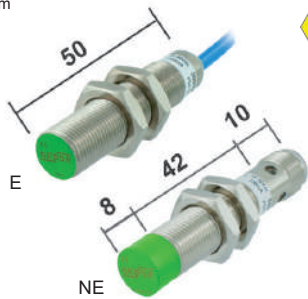

Distance	CE	Feeding	Output	Mount.	Connection		Tube Length	Code		
2 mm	NAMUR	7 to 12Vdc	NC	E	Cable	2 wires	50 mm	PS2-12GM50-N-Ex		
			NC/Illuminated					PS2-12GI50-N-L-Ex		
4 mm			NC		NC/Illuminated	NE		Cable	2 wires	PS2-12GM50-N-V1-Ex
										NC
Connector			4 pins	PS4-12GM50-N-V1-Ex						

M18 NAMUR Line

Ø 18 mm

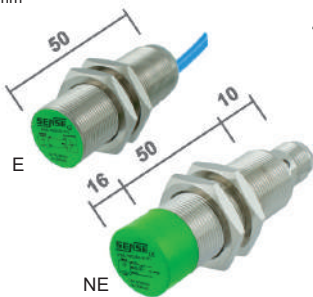

Distance	CE	Feeding	Output	Mount.	Connection		Tube Length	Code		
5 mm	NAMUR	7 to 12Vdc	NC	E	Cable	2 wires	50 mm	PS5-18GM50-N-Ex		
			NC/Illuminated					PS5-18GI50-N-L-Ex		
8 mm			NC		NC/Illuminated	NE		Cable	2 wires	PS5-18GM50-N-V1-Ex
										NC
Connector			4 pins	PS8-18GI50-N-L-Ex						
				PS8-18GM50-N-V1-Ex						

M30 NAMUR Line

Ø 30 mm

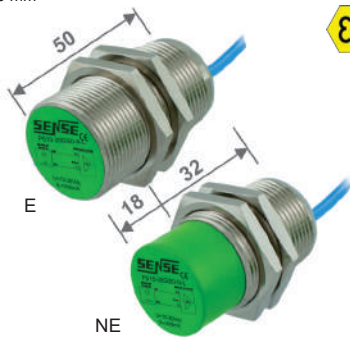

Distance	CE	Feeding	Output	Mount.	Connection		Tube Length	Code		
10 mm	NAMUR	7 to 12Vdc	NC	E	Cable	2 wires	50 mm	PS10-30GM50-N-Ex		
			NC/Illuminated					PS10-30GI50-N-L-Ex		
15 mm			NC		NC/Illuminated	NE		Cable	2 wires	PS10-30GM50-N-V1-Ex
										NC
Connector			4 pins	PS15-30GI50-N-L-Ex						
				PS15-30GM50-N-V1-Ex						

E - Flush NE - Non-flush

Note 1: For detailed model dimensions, see our website www.sense.com.br

Note 2: The codes in the NAMUR range with an Ex ending are certified, see our website www.sense.com.br

Obs: Illustrative photos

Connection Diagram

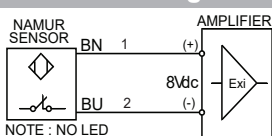

Types of Tubes

GM nickel-plated brass, side LED

GP thermoplastic with fiberglass

GI nickel-plated brass, illuminated rear

GX stainless steel

Note: Use in areas containing flammable gases and vapors and combustible dust.

M8 Connector

V8

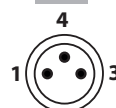

M12 Connector

V1

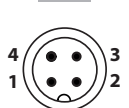



Tubular Inductive Sensors - IP69K

Combustible Dust Atmosphere Certified



Ø4,0 and Ø5,0 Standard Line

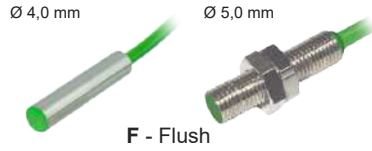

Distance	CE	Feeding	Output	Output	Mount.	Connection		Tube Length	Code
						Cable	3 wires		
0,8 mm	NPN	10 to 30 Vdc	NO	100 mA	Flush	Cable	3 wires	25 mm	PS0,8F-4-25-E2
						Pigtail	3 pins		PS0,8F-4-25-E2-PV83
						Cable	3 wires		PS0,8F-5GM25-E2
						Pigtail	3 pins		PS0,8F-5GM25-E2-PV83

Ø6,5 and Ø8,0 Standard Line

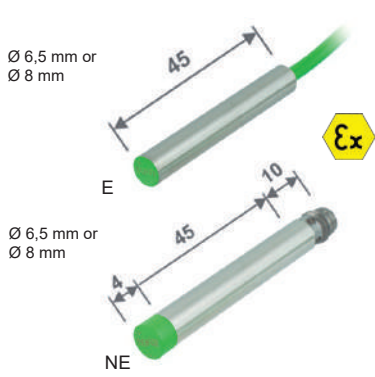

Distance	CE	Feeding	Output	Output	Mount.	Connection		Tube Length	Code
						Cable	3 wires		
1,5 mm	NPN	10 to 30 Vdc	NO	100 mA	E	Cable	3 wires	45 mm	PS1,5-6,5-45-E-Ex
						Connector	3 pins		PS1,5-8-45-E-Ex
2 mm						Cable	3 wires		PS1,5-6,5-45-E-V8
						Connector	3 pins		PS2-6,5-45-E-Ex
1,5 mm	PNP	10 to 30 Vdc	NO	100 mA	E	Cable	3 wires	45 mm	PS1,5-6,5-45-E2-Ex
						Connector	3 pins		PS1,5-8-45-E2-Ex
2 mm						Cable	3 wires		PS1,5-6,5-45-E2-V8
						Connector	3 pins		PS2-6,5-45-E2-Ex
2 mm	PNP	10 to 30 Vdc	NO	100 mA	NE	Cable	3 wires	45 mm	PS2-6,5-45-E2-Ex
						Connector	3 pins		PS2-8-45-E2-Ex
2 mm						Cable	3 wires		PS2-6,5-45-E2-V8
						Connector	3 pins		PS2-8-45-E2-V8

M8 Standard Line

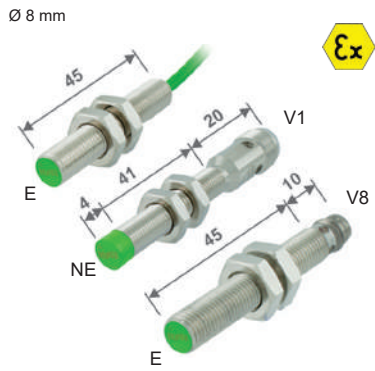

Distance	CE	Feeding	Output	Output	Mount.	Connection		Tube Length	Code
						Cable	3 wires		
1,5 mm	NPN	10 to 30 Vdc	NO	100 mA	E	Connector	4 pins	45 mm	PS1,5-8GM45-E-Ex
						Connector	3 pins		PS1,5-8GI45-E-V1-Ex
	PNP					Cable	3 wires		PS1,5-8GM45-E2-Ex
						Connector	4 pins		PS1,5-8GI45-E2-V1-Ex
2 mm	NPN	10 to 30 Vdc	NO	100 mA	NE	Connector	3 pins	45 mm	PS1,5-8GM45-E2-V8
						Cable	3 wires		PS2-8GM45-E-Ex
						Connector	4 pins		PS2-8GI45-E-V1-Ex
						Cable	3 pins		PS2-8GM45-E-V8
	PNP	10 to 30 Vdc	NO	100 mA	E	Connector	4 pins	45 mm	PS2-8GM45-E-Ex
						Cable	3 wires		PS2-8GI45-E-V1-Ex
						Connector	4 pins		PS2-8GM45-E2-Ex
						Cable	3 pins		PS2-8GM45-E2-V8
NPN	10 to 30 Vdc	NO	200 mA	E	Connector	3 pins	45 mm	PS2F-8GM45-E	
					Cable	3 wires		PS2F-8GM45-E-V8	
					Connector	3 pins		PS2F-8GM45-E2	
					Cable	3 wires		PS2F-8GM45-E2-V8	

M12 Standard Line

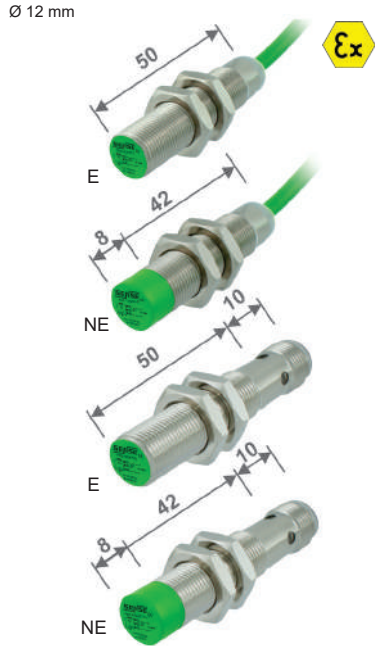

Distance	CE	Feeding	Output	Output	Mount.	Connection		Tube Length	Code
						Cable	3 wires		
2 mm	NPN	10 to 30 Vdc	NO	200 mA	E	Connector	4 pins	50 mm	PS2-12GI50-E-Ex
						Connector	4 pins		PS2-12GI50-E-V1-Ex
						Cable	4 wires		PS2-12GI50-A-Ex
	PNP					Connector	4 pins		PS2-12GI50-A-V1-Ex
						Cable	3 wires		PS2-12GI50-E2-Ex
						Connector	4 pins		PS2-12GI50-E2-V1-Ex
4 mm	NPN	10 to 30 Vdc	NO	200 mA	NE	Connector	4 pins	50 mm	PS4-12GI50-E-Ex
						Connector	4 pins		PS4-12GI50-E-V1-Ex
						Cable	4 wires		PS4-12GI50-A-Ex
	PNP					Connector	4 pins		PS4-12GI50-A-V1-Ex
						Cable	3 wires		PS4-12GI50-E2-Ex
						Connector	4 pins		PS4-12GI50-E2-V1-Ex
2 mm	DC	10 to 60 Vdc	NO	200 mA	E	Connector	4 pins	50 mm	PS4-12GI50-E-Ex
						Connector	4 pins		PS4-12GI50-E-V1-Ex
						Cable	2 wires		PS2-12GI50-N4-Ex
	PNP					Connector	4 pins		PS2-12GI50-N4-V1-Ex
						Cable	2 wires		PS2-12GI50-N5-Ex
						Connector	4 pins		PS2-12GI50-N5-V1-Ex
4 mm	DC	10 to 60 Vdc	NO	200 mA	NE	Connector	4 pins	50 mm	PS4-12GI50-N4-Ex
						Connector	4 pins		PS4-12GI50-N4-V1-Ex
						Cable	2 wires		PS4-12GI50-N5-Ex
	AC					Connector	4 pins		PS4-12GI50-N5-V1-Ex
						Cable	2 wires		PS2-12GI50-WA-Ex
						Connector	4 pins		PS2-12GI50-WA-V1-Ex
2 mm	AC	20 to 250 Vac	NO	200 mA	E	Connector	4 pins	50 mm	PS2-12GI50-WF-Ex
						Connector	4 pins		PS2-12GI50-WF-V1-Ex
						Cable	2 wires		PS4-12GI50-WA-Ex
	PNP					Connector	4 pins		PS4-12GI50-WA-V1-Ex
						Cable	2 wires		PS4-12GI50-WF-Ex
						Connector	4 pins		PS4-12GI50-WF-V1-Ex

E - Flush NE - Non-flush

Obs: Illustrative photos

Note 1: Connection diagram page 4. **Note 2:** Tube material page 5. **Note 3:** Connector design page 2. **Note 4:** Ex: Use in areas containing combustible dust.

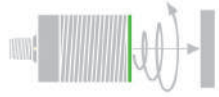

Tubular Inductive Sensors - IP69K

Combustible Dust Atmosphere Certified



M18 Standard Line

Ø 18 mm

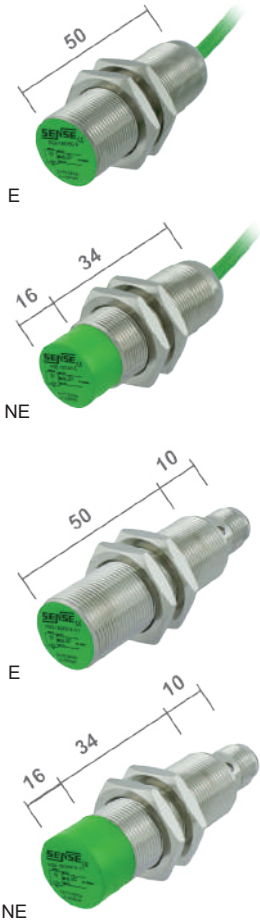

E - Flush NE - Non-flush

Obs: Illustrative photos

Distance	CE	Feeding	Output	Output	Mount.	Connection	Tube Length	Code	
5 mm	NPN	10 to 30 Vdc	NO	200 mA	E	Cable	50 mm	PS5-18GI50-E-Ex	
						Connector		PS5-18GI50-E-V1-Ex	
						Cable		PS5-18GI50-A-Ex	
						Connector		PS5-18GI50-A-V1-Ex	
8 mm	NPN		NO		NO	NE		Cable	PS8-18GI50-E-Ex
								Connector	PS8-18GI50-E-V1-Ex
								Cable	PS8-18GI50-A-Ex
								Connector	PS8-18GI50-A-V1-Ex
5 mm	PNP	NO	NO	E	Cable	PS5-18GI50-E2-Ex			
					Connector	PS5-18GI50-E2-V1-Ex			
					Cable	PS5-18GI50-A2-Ex			
					Connector	PS5-18GI50-A2-V1-Ex			
8 mm	PNP	NO	NO	NE	Cable	PS8-18GI50-E2-Ex			
					Connector	PS8-18GI50-E2-V1-Ex			
					Cable	PS8-18GI50-A2-Ex			
					Connector	PS8-18GI50-A2-V1-Ex			
5 mm	DC	10 to 60 Vdc	NO	100 mA	E	Cable	PS5-18GI50-N4-Ex		
						Connector	PS5-18GI50-N4-V1-Ex		
						Cable	PS5-18GI50-N5-Ex		
						Connector	PS5-18GI50-N5-V1-Ex		
8 mm	DC		NO		NO	NE	Cable	PS8-18GI50-N4-Ex	
							Connector	PS8-18GI50-N4-V1-Ex	
							Cable	PS8-18GI50-N5-Ex	
							Connector	PS8-18GI50-N5-V1-Ex	
5 mm	AC	20 to 250 Vac	NO	500 mA	E	Cable	PS5-18GI50-WA-Ex		
						Connector	PS5-18GI50-WA-V1-Ex		
						Cable	PS5-18GI50-WF-Ex		
						Connector	PS5-18GI50-WF-V1-Ex		
8 mm	AC		NO		NO	NE	Cable	PS8-18GI50-WA-Ex	
							Connector	PS8-18GI50-WA-V1-Ex	
							Cable	PS8-18GI50-WF-Ex	
							Connector	PS8-18GI50-WF-V1-Ex	
5 mm	DC/ AC	20 to 250 Vac or Vdc	NO	300 mA	E	Cable	PS5-18GI50-W3A-Ex		
						Connector	PS5-18GI50-W3A-V1-Ex		
						Cable	PS5-18GI50-W3F-Ex		
						Connector	PS5-18GI50-W3F-V1-Ex		
8 mm	DC/ AC		NO		NO	NE	Cable	PS8-18GI50-WA-Ex	
							Connector	PS8-18GI50-WA-V1-Ex	
							Cable	PS8-18GI50-WF-Ex	
							Connector	PS8-18GI50-WF-V1-Ex	
5 mm	DC/ AC	NO	NO	E	Cable	PS5-18GI50-W3A-Ex			
					Connector	PS5-18GI50-W3A-V1-Ex			
					Cable	PS5-18GI50-W3F-Ex			
					Connector	PS5-18GI50-W3F-V1-Ex			
8 mm	DC/ AC	NO	NO	NE	Cable	PS8-18GI50-WA-Ex			
					Connector	PS8-18GI50-WA-V1-Ex			
					Cable	PS8-18GI50-WF-Ex			
					Connector	PS8-18GI50-WF-V1-Ex			
5 mm	DC/ AC	NO	NO	E	Cable	PS5-18GI70-UA-Ex			
					Connector	PS5-18GI70-UA-V1-Ex			
					Cable	PS5-18GI70-UF-Ex			
					Connector	PS5-18GI70-UF-V1-Ex			
8 mm	DC/ AC	NO	NO	NE	Cable	PS8-18GI70-UA-Ex			
					Connector	PS8-18GI70-UA-V1-Ex			
					Cable	PS8-18GI70-UF-Ex			
					Connector	PS8-18GI70-UF-V1-Ex			

Connection Diagram

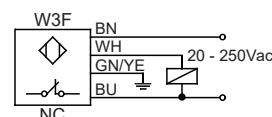
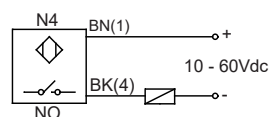
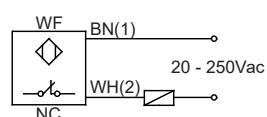
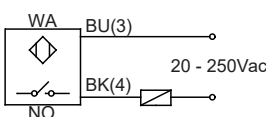
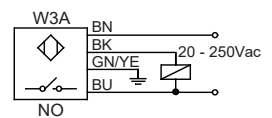
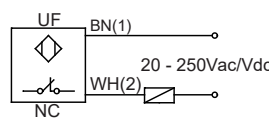
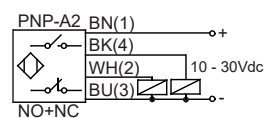
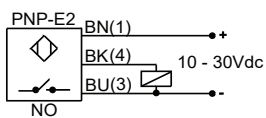
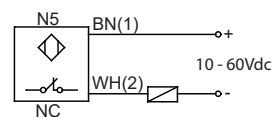
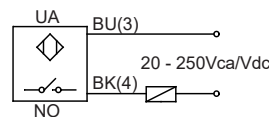
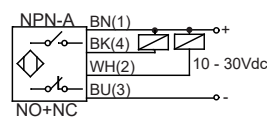
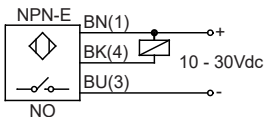

M12 Connector

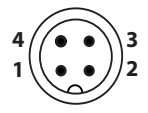

V1

Note 1: Tube material page 5.

Note 2: For detailed model dimensions, see our website www.sense.com.br. Note 3: Use in areas containing combustible dust.

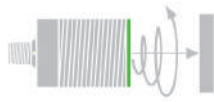

Tubular Inductive Sensors - IP69K

Combustible Dust Atmosphere Certified



M30 Standard Line

Ø 30 mm

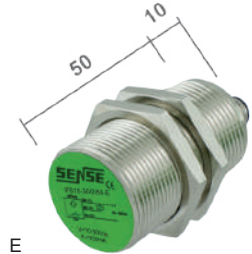

Distance	CE	Feeding	Output	Output	Mount.	Connection		Tube Length	Code	
10 mm	NPN	10 to 30 Vdc	NO	200 mA	E	Cable	3 wires	50 mm	PS10-30GI50-E-Ex	
			NO+NC			Connector	4 pins		PS10-30GI50-E-V1-Ex	
15 mm			NO			Cable	4 wires		PS10-30GI50-A-Ex	
			NO+NC			Connector	4 pins		PS10-30GI50-A-V1-Ex	
10 mm	PNP		10 to 60 Vdc		NO	E	Cable		3 wires	PS15-30GI50-E-Ex
					NO+NC		Connector		4 pins	PS15-30GI50-E-V1-Ex
15 mm					NO		Cable		4 wires	PS15-30GI50-A-Ex
					NO+NC		Connector		4 pins	PS15-30GI50-A-V1-Ex
10 mm	DC	10 to 60 Vdc		NO	E	Cable	2 wires		PS10-30GI50-E2-Ex	
				NC		Connector	4 pins		PS10-30GI50-E2-V1-Ex	
15 mm				NO		Cable	4 wires		PS10-30GI50-A2-Ex	
				NC		Connector	4 pins		PS10-30GI50-A2-V1-Ex	
10 mm	AC		20 to 250 Vac	NO	E	Cable	2 wires		PS10-30GI50-N4-Ex	
				NC		Connector	4 pins		PS10-30GI50-N4-V1-Ex	
15 mm				NO		Cable	2 wires		PS10-30GI50-N5-Ex	
				NC		Connector	4 pins		PS10-30GI50-N5-V1-Ex	
10 mm	AC	20 to 250 Vac		NO	E	Cable	2 wires	PS10-30GI50-WA-Ex		
				NC		Connector	4 pins	PS10-30GI50-WA-V1-Ex		
15 mm				NO		Cable	2 wires	PS10-30GI50-WF-Ex		
				NC		Connector	4 pins	PS10-30GI50-WF-V1-Ex		
10 mm	AC		20 to 250 Vac	NO	E	Cable	3 wires	PS10-30GI50-W3A-Ex		
				NC		Connector	4 pins	PS10-30GI50-W3F-Ex		
15 mm				NO		Connector	4 pins	PS15-30GI50-WA-Ex		
				NC		Connector	4 pins	PS15-30GI50-WA-V1-Ex		
10 mm	AC	20 to 250 Vac		NO	E	Cable	2 wires	PS15-30GI50-WF-Ex		
				NC		Connector	4 pins	PS15-30GI50-WF-V1-Ex		
15 mm				NO		Cable	3 wires	PS15-30GI50-W3A-Ex		
				NC		Connector	4 pins	PS15-30GI50-W3F-Ex		
10 mm	DC/AC		20 to 250 Vac or Vdc	NO	E	Connector	4 pins	PS10-30GI70-UA-Ex		
				NC		Cable	2 wires	PS10-30GI70-UA-V1-Ex		
15 mm				NO		Connector	4 pins	PS10-30GI70-UF-Ex		
				NC		Connector	4 pins	PS10-30GI70-UF-V1-Ex		
10 mm	DC/AC	20 to 250 Vac or Vdc		NO	NE	Cable	2 wires	PS15-30GI70-UA-Ex		
				NC		Connector	4 pins	PS15-30GI70-UA-V1-Ex		
15 mm				NO		Cable	2 wires	PS15-30GI70-UF-Ex		
				NC		Connector	4 pins	PS15-30GI70-UF-V1-Ex		

Obs: Illustrative photos

E - Flush NE - Non-flush

Connection Diagram

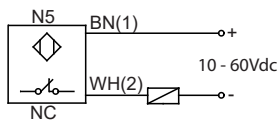
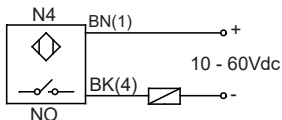
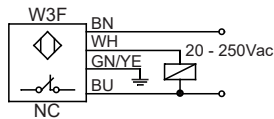
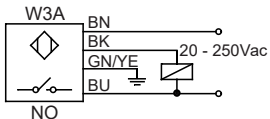

M12 Connector



V1

Types of Tubes

GM	nickel-plated brass, side LED
GI	nickel-plated brass, illuminated rear
GP	thermoplastic with fiberglass
GT	brass with PTFE bath
GX	stainless steel

Note 1: For detailed model dimensions, see our website www.sense.com.br

Note 2: Connection diagram E, E2, A, A2, WA, WF, UA, UF - Page 4.

Note 3: Use in areas containing combustible dust.

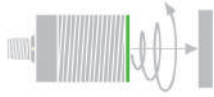

Tubular Inductive Sensors

Combustible Dust Atmosphere Certified



M12 Increased and Extended Distance Line

Ø 12 mm



Distance	CE	Feeding	Output	Output	Mount.	Connection	Tube Length	Code	
4 mm	NPN	10 to 30 Vdc	NO	200 mA	SE	Cable	3 wires	50 mm	PSL4-12GI50-E-Ex
						Connector	4 pins		PSL4-12GI50-E-V1-Ex
	PNP					Cable	3 wires		PSL4-12GI50-E2-Ex
						Connector	4 pins		PSL4-12GI50-E2-V1-Ex
6 mm	NPN				SE	Cable	3 wires		PSL6-12GI50-E-Ex
						Connector	4 pins		PSL6-12GI50-E-V1-Ex
	PNP				NE	Cable	3 wires		PSL6-12GI50-E2-Ex
						Connector	4 pins		PSL6-12GI50-E2-V1-Ex
	NPN	SE	Cable	3 wires	PSE6-12GI50-E-Ex				
			Connector	4 pins	PSE6-12GI50-E-V1-Ex				
PNP	NE	Cable	3 wires	PSE6-12GI50-E2-Ex					
		Connector	4 pins	PSE6-12GI50-E2-V1-Ex					
10 mm	NPN	NE	Cable	3 wires	PSE10-12GI50-E-Ex				
			Connector	4 pins	PSE10-12GI50-E-V1-Ex				
	PNP		Cable	3 wires	PSE10-12GI50-E2-Ex				
			Connector	4 pins	PSE10-12GI50-E2-V1-Ex				

M18 Increased and Extended Distance Line

Ø 18 mm



Distance	CE	Feeding	Output	Output	Mount.	Connection	Tube Length	Code	
8 mm	NPN	10 to 30 Vdc	NO	200 mA	SE	Cable	3 wires	50 mm	PSL8-18GI50-E-Ex
						Connector	4 pins		PSL8-18GI50-E-V1-Ex
	PNP					Cable	3 wires		PSL8-18GI50-E2-Ex
						Connector	4 pins		PSL8-18GI50-E2-V1-Ex
12 mm	NPN				SE	Cable	3 wires		PSL12-18GI50-E-Ex
						Connector	4 pins		PSL12-18GI50-E-V1-Ex
	PNP				NE	Cable	3 wires		PSL12-18GI50-E2-Ex
						Connector	4 pins		PSL12-18GI50-E2-V1-Ex
	NPN	SE	Cable	3 wires	PSE12-18GI50-E-Ex				
			Connector	4 pins	PSE12-18GI50-E-V1-Ex				
PNP	NE	Cable	3 wires	PSE12-18GI50-E2-Ex					
		Connector	4 pins	PSE12-18GI50-E2-V1-Ex					
20 mm	NPN	NE	Cable	3 wires	PSE20-18GI50-E-Ex				
			Connector	4 pins	PSE20-18GI50-E-V1-Ex				
	PNP		Cable	3 wires	PSE20-18GI50-E2-Ex				
			Connector	4 pins	PSE20-18GI50-E2-V1-Ex				

M30 Increased and Extended Distance Line

Ø 30 mm

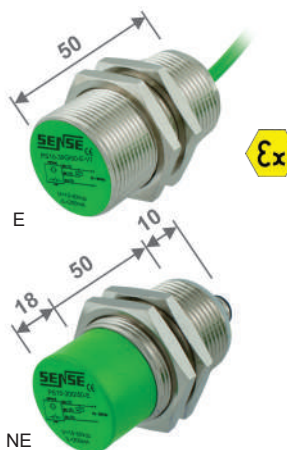

Distance	CE	Feeding	Output	Output	Mount.	Connection	Tube Length	Code	
15 mm	NPN	10 to 30 Vdc	NO	200 mA	SE	Cable	3 wires	50 mm	PSL15-30GI50-E-Ex
						Connector	4 pins		PSL15-30GI50-E-V1-Ex
	PNP					Cable	3 wires		PSL15-30GI50-E2-Ex
						Connector	4 pins		PSL15-30GI50-E2-V1-Ex
24 mm	NPN				SE	Cable	3 wires		PSL24-30GI50-E-Ex
						Connector	4 pins		PSL24-30GI50-E-V1-Ex
	PNP				NE	Cable	3 wires		PSL24-30GI50-E2-Ex
						Connector	4 pins		PSL24-30GI50-E2-V1-Ex
22 mm	NPN	NE	Cable	3 wires	PSE22-30GI50-E-Ex				
			Connector	4 pins	PSE22-30GI50-E-V1-Ex				
	PNP		Cable	3 wires	PSE22-30GI50-E2-Ex				
			Connector	4 pins	PSE22-30GI50-E2-V1-Ex				
40 mm	NPN	NE	Cable	3 wires	PSE40-30GI50-E-Ex				
			Connector	4 pins	PSE40-30GI50-E-V1-Ex				
	PNP		Cable	3 wires	PSE40-30GI50-E2-Ex				
			Connector	4 pins	PSE40-30GI50-E2-V1-Ex				

Obs: Illustrative photos

E - Flush NE - Non-flush

Note 1 : For detailed model dimensions, see our website www.sense.com.br Note 2: Use in areas containing combustible dust.

Connection Diagram

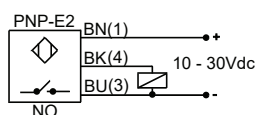
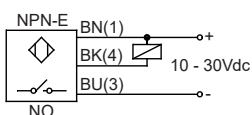

M12 Connector



V1

Types of Tubes

GI	nickel-plated brass, illuminated rear
GT	brass with PTFE bath
GX	stainless steel



Tubular Inductive Sensors

Combustible Dust Atmosphere Certified



M12, M18 and M30 Metallic Front Line



Distance	CE	Feeding	Output	Output	Mount.	Connection		Tube Length	Code
2 mm	NPN	10 to 30 Vdc	NO	200 mA	E	Cable	3 wires	50 mm	PSX2-12GX50-E-Ex
						Connector	4 pins		PSX2-12GX50-E-V1-Ex
	PNP					Cable	3 wires		PSX2-12GX50-E2-Ex
						Connector	4 pins		PSX2-12GX50-E2-V1-Ex
5 mm	NPN					Cable	3 wires		PSX5-18GX50-E-Ex
						Connector	4 pins		PSX5-18GX50-E-V1-Ex
	PNP					Cable	3 wires		PSX5-18GX50-E2-Ex
						Connector	4 pins		PSX5-18GX50-E2-V1-Ex
8 mm	NPN	Cable	3 wires	PSX8-30GX50-Ex					
		Connector	4 pins	PSX8-30GX50-E-V1-Ex					
	PNP	Cable	3 wires	PSX8-30GX50-E2-Ex					
		Connector	4 pins	PSX8-30GX50-E2-V1-Ex					

E - Flush

M12, M18 and M30 Analog Output Line

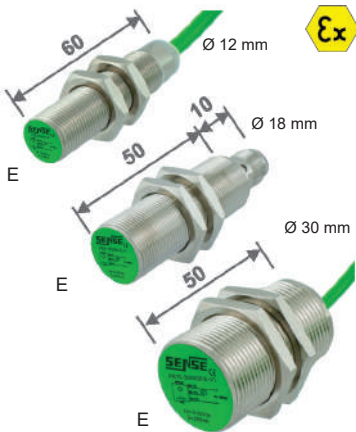

Distance	CE	Feeding	Output	Mount.	Connection		Tube Length	Code	
2 mm	Analog	15 to 30 Vdc	4 to 20 mA	E	Cable	3 wires	60 mm	PA2-12GI60-AN-Ex	
					Connector	Connector		PA2-12GI60-AN-V1-Ex	
4 mm					Cable	3 wires	50 mm	PA4-18GI50-AN-Ex	
					Connector	Connector		PA4-18GI50-AN-V1-Ex	
					8 mm	Cable		3 wires	PA8-30GI50-AN-Ex
						Connector		Connector	PA8-30GI50-AN-V1-Ex

E - Flush

M12, M18 and M30 High Temperature Line up to 120 °C



Distance	CE	Feeding	Output	Output	Mount.	Connection		Tube Length	Código
2 mm	NPN	10 to 30 Vdc	NO	200 mA	E	Cable	3 wires	50 mm	PST2-12GX50-E
									PNP
5 mm	NPN								PST5-18GX50-E
									PNP
10 mm	NPN								PST10-30GX50-E
									PNP

E - Flush

Note 1: For detailed model dimensions, see our website www.sense.com.br

Note 2: Use in areas containing combustible dust.

Obs: Illustrative photos

Connection Diagram

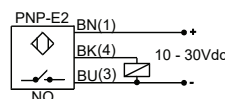
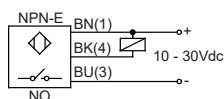
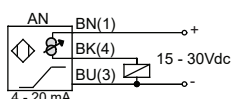

M12 Connector



V1

Types of Tubes

GI	nickel-plated brass, illuminated rear
GX	stainless steel



Non-tubular Inductive Sensors

Combustible Dust Atmosphere Certified



Pentakon Line - U1

PS15, PS20, PS30

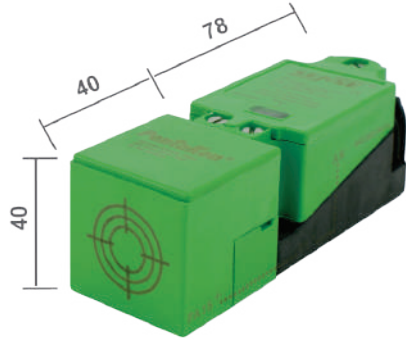

PS-40

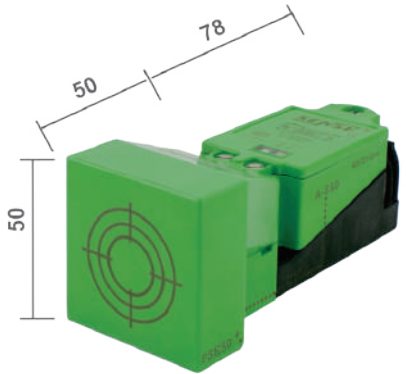

Distance	CE	Feeding	Output	Output	Mount.	Connection	Code
15 mm	NAMUR	7 to 12 Vdc	NC	-	E	Screw Terminals	2 term. PS15+U1+N-Ex
	NPN	10 to 30 Vdc	NO	200 mA			3 term. PS15+U1+E-Ex
			NO+NC				4 term. PS15+U1+A-Ex
	PNP	10 to 30 Vdc	NO	200 mA			3 term. PS15+U1+E2-Ex
			NO+NC				4 term. PS15+U1+A2-Ex
	CC	10 to 60 Vdc	NO or NC	100 mA			2 term. PS15+U1+N54
CA	20 to 250 Vac	500 mA		3 term. PS15+U1+W-Ex			
20 mm	NPN	10 to 30 Vdc	NO	200 mA	NE	Screw Terminals	PS15+U1+W3
			NO+NC				2 term. PS15+U1+N54
	PNP	10 to 30 Vdc	NO	200 mA			3 term. PS15+U1+E-Ex
			NO+NC				4 term. PS15+U1+A-Ex
	CC	10 to 60 Vdc	NO or NC	100 mA			3 term. PS15+U1+E2-Ex
	CA	20 to 250 Vac		500 mA			4 term. PS15+U1+A2-Ex
30 mm	NPN	10 to 30 Vdc	NO	200 mA	NE	Screw Terminals	PS20+U1+N54
			NO+NC				2 term. PS20+U1+N-Ex
	PNP	10 to 30 Vdc	NO	200 mA			3 term. PS20+U1+E-Ex
			NO+NC				4 term. PS20+U1+A-Ex
	CC	10 to 60 Vdc	NO or NC	100 mA			3 term. PS20+U1+E2-Ex
	CA	20 to 250 Vac		500 mA			4 term. PS20+U1+A2-Ex
40 mm	NPN	10 to 30 Vdc	NO	200 mA	NE	Screw Terminals	PS20+U1+W3
			NO+NC				2 term. PS20+U1+N54
	PNP	10 to 30 Vdc	NO	200 mA			3 term. PS20+U1+E-Ex
			NO+NC				4 term. PS20+U1+A-Ex
	CC	10 to 60 Vdc	NO or NC	100 mA			3 term. PS20+U1+E2-Ex
	CA	20 to 250 Vac		500 mA			4 term. PS20+U1+A2-Ex
40 mm	NPN	10 to 30 Vdc	NO	200 mA	NE	Screw Terminals	PS30+U1+N54
			NO+NC				2 term. PS30+U1+N-Ex
	PNP	10 to 30 Vdc	NO	200 mA			3 term. PS30+U1+E-Ex
			NO+NC				4 term. PS30+U1+A-Ex
	CC	10 to 60 Vdc	NO or NC	100 mA			3 term. PS30+U1+E2-Ex
	CA	20 to 250 Vac		500 mA			4 term. PS30+U1+A2-Ex
40 mm	NPN	10 to 30 Vdc	NO	200 mA	NE	Screw Terminals	PS30+U1+W3
			NO+NC				2 term. PS30+U1+N54
	PNP	10 to 30 Vdc	NO	200 mA			3 term. PS30+U1+E-Ex
			NO+NC				4 term. PS30+U1+A-Ex
	CC	10 to 60 Vdc	NO or NC	100 mA			3 term. PS30+U1+E2-Ex
	CA	20 to 250 Vac		500 mA			4 term. PS30+U1+A2-Ex
40 mm	NPN	10 to 30 Vdc	NO	200 mA	NE	Screw Terminals	PS40+U1+N54
			NO+NC				2 term. PS40+U1+N-Ex
	PNP	10 to 30 Vdc	NO	200 mA			3 term. PS40+U1+E-Ex
			NO+NC				4 term. PS40+U1+A-Ex
	CC	10 to 60 Vdc	NO or NC	100 mA			3 term. PS40+U1+E2-Ex
	CA	20 to 250 Vac		500 mA			4 term. PS40+U1+A2-Ex
40 mm	NPN	10 to 30 Vdc	NO	200 mA	NE	Screw Terminals	PS40+U1+W3
			NO+NC				2 term. PS40+U1+N54
	PNP	10 to 30 Vdc	NO	200 mA			3 term. PS40+U1+E-Ex
			NO+NC				4 term. PS40+U1+A-Ex
	CC	10 to 60 Vdc	NO or NC	100 mA			3 term. PS40+U1+E2-Ex
	CA	20 to 250 Vac		500 mA			4 term. PS40+U1+A2-Ex
40 mm	NPN	10 to 30 Vdc	NO	200 mA	NE	Screw Terminals	PS40+U1+W3
			NO+NC				2 term. PS40+U1+N54
	PNP	10 to 30 Vdc	NO	200 mA			3 term. PS40+U1+E-Ex
			NO+NC				4 term. PS40+U1+A-Ex
	CC	10 to 60 Vdc	NO or NC	100 mA			3 term. PS40+U1+E2-Ex
	CA	20 to 250 Vac		500 mA			4 term. PS40+U1+A2-Ex
40 mm	NPN	10 to 30 Vdc	NO	200 mA	NE	Screw Terminals	PS40+U1+W3
			NO+NC				2 term. PS40+U1+N54
	PNP	10 to 30 Vdc	NO	200 mA			3 term. PS40+U1+E-Ex
			NO+NC				4 term. PS40+U1+A-Ex
	CC	10 to 60 Vdc	NO or NC	100 mA			3 term. PS40+U1+E2-Ex
	CA	20 to 250 Vac		500 mA			4 term. PS40+U1+A2-Ex
40 mm	NPN	10 to 30 Vdc	NO	200 mA	NE	Screw Terminals	PS40+U1+W3
			NO+NC				2 term. PS40+U1+N54
	PNP	10 to 30 Vdc	NO	200 mA			3 term. PS40+U1+E-Ex
			NO+NC				4 term. PS40+U1+A-Ex
	CC	10 to 60 Vdc	NO or NC	100 mA			3 term. PS40+U1+E2-Ex
	CA	20 to 250 Vac		500 mA			4 term. PS40+U1+A2-Ex
40 mm	NPN	10 to 30 Vdc	NO	200 mA	NE	Screw Terminals	PS40+U1+W3
			NO+NC				2 term. PS40+U1+N54
	PNP	10 to 30 Vdc	NO	200 mA			3 term. PS40+U1+E-Ex
			NO+NC				4 term. PS40+U1+A-Ex
	CC	10 to 60 Vdc	NO or NC	100 mA			3 term. PS40+U1+E2-Ex
	CA	20 to 250 Vac		500 mA			4 term. PS40+U1+A2-Ex
40 mm	NPN	10 to 30 Vdc	NO	200 mA	NE	Screw Terminals	PS40+U1+W3
			NO+NC				2 term. PS40+U1+N54
	PNP	10 to 30 Vdc	NO	200 mA			3 term. PS40+U1+E-Ex
			NO+NC				4 term. PS40+U1+A-Ex
	CC	10 to 60 Vdc	NO or NC	100 mA			3 term. PS40+U1+E2-Ex
	CA	20 to 250 Vac		500 mA			4 term. PS40+U1+A2-Ex
40 mm	NPN	10 to 30 Vdc	NO	200 mA	NE	Screw Terminals	PS40+U1+W3
			NO+NC				2 term. PS40+U1+N54
	PNP	10 to 30 Vdc	NO	200 mA			3 term. PS40+U1+E-Ex
			NO+NC				4 term. PS40+U1+A-Ex
	CC	10 to 60 Vdc	NO or NC	100 mA			3 term. PS40+U1+E2-Ex
	CA	20 to 250 Vac		500 mA			4 term. PS40+U1+A2-Ex
40 mm	NPN	10 to 30 Vdc	NO	200 mA	NE	Screw Terminals	PS40+U1+W3
			NO+NC				2 term. PS40+U1+N54
	PNP	10 to 30 Vdc	NO	200 mA			3 term. PS40+U1+E-Ex
			NO+NC				4 term. PS40+U1+A-Ex
	CC	10 to 60 Vdc	NO or NC	100 mA			3 term. PS40+U1+E2-Ex
	CA	20 to 250 Vac		500 mA			4 term. PS40+U1+A2-Ex

Unikon Line - D1

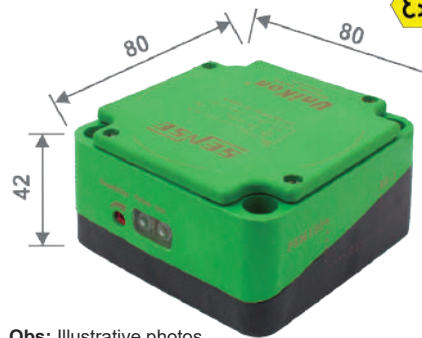

Distance	CE	Feeding	Output	Output	Mount.	Connection	Code
40 mm	NAMUR	7 to 12 Vdc	NC	-	E	Screw Terminals	2 term. PS40+D1+N-Ex
	NPN	10 to 30 Vdc	NO+NC	200 mA			4 term. PS40+D1+A
			NO+NC	500 mA			PS40+D1+A2
60 mm	NAMUR	7 to 12 Vdc	NC	-	NE	Screw Terminals	PS40+D1+W
	NPN	10 to 30 Vdc	NO+NC	200 mA			2 term. PS60+D1+N-Ex
			NO+NC	500 mA			PS60+D1+N-J-Ex
AC	20 to 250 Vac	NO or NC	500 mA	500 mA	4 term. PS60+D1+A		
					PS60+D1+A2		
AC	20 to 250 Vac	NO or NC	500 mA	500 mA	2 term. PS60+D1+W		

Obs: Illustrative photos

E - Flush NE - Non-flush J - Sensitivity-adjustable model

Connection Diagram

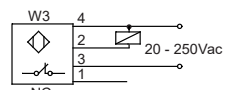
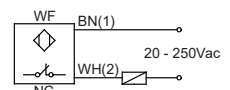
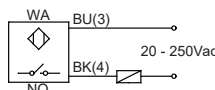
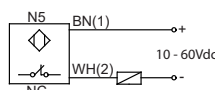
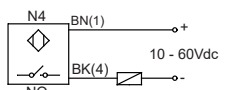
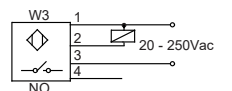
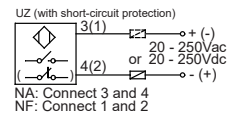
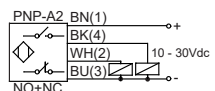
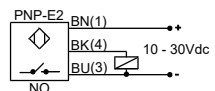
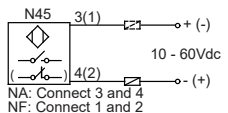
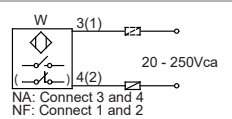
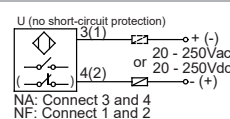
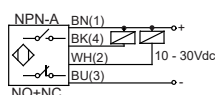
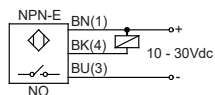

Note 1: For detailed model dimensions, see our website www.sense.com.br Note 2: Use in areas containing combustible dust.



Non-tubular Inductive Sensors

Gas and Combustible Dust Atmosphere Certified



Slot Line - RS

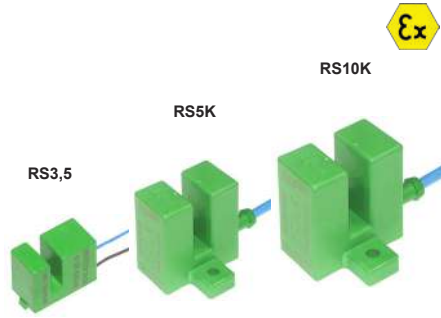

Groove	CE	Feeding	Output	Output	Wire Number	Mount.	Connection	Code				
3,5 mm	NAMUR	7 to 12 Vdc	NC	-	2	NE	Cable	RS3,5-N/SX-Ex				
								RS5K-N/SX-Ex				
5 mm	NPN	10 to 30 Vdc	NO	200 mA	3			RS5K-E/SZ				
								RS5K-E2/SZ				
10 mm	NAMUR	7 to 12 Vdc	NC	-	2			RS10K-N/SX-Ex				
								NPN	10 to 30 Vdc	NO+NC	200 mA	RS10K-A/SZ
												RS10K-A2/SZ
	PNP	20 to 250 Vac	NO	500 mA	2			RS10K-WA/SY				
								NC	RS10K-WF/SY			

Ring Line - AS

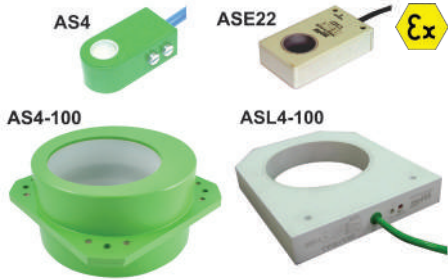

Distance	CE	Feeding	Output	Output	Wire Number	Mount.	Connection	Code
10 mm	NAMUR	7 to 12 Vdc	NC	-	2	NE	Cable	AS-10-N/SX
25mm	PNP	10 to 30 Vdc	NO	200 mA	3			ASE22-25-E2/SZ
100 mm			NO+NC		4			AS4-100-A2/24Y
100 mm	NPN	10 to 30 Vdc	NO+ NC	200 mA	4			ASL4-100-A-J
								PNP

NE - Non-flush

Linha F

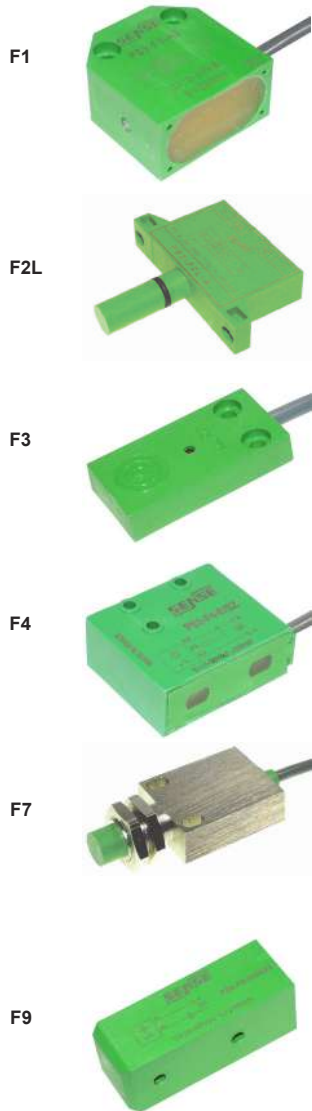

Distance	CE	Feeding	Output	Output	Contact	Mount.	Connection	Código					
5 mm	NAMUR	7 to 12 Vdc	NC	-	2	E	Cable	PS5-F1-N					
							Terminals	PS5-F1-N-VT					
	NPN	10 to 30 Vdc	NO+NC	200 mA	4		Cable	PS5-F1-A					
							Terminals	PS5-F1-A-VT					
							PNP	20 to 250 Vca	NO	500 mA	2	Connector	PS5-F1-A-V1
												PS5-F1-A2-V1	
							AC	20 to 250 Vca	NC	500 mA	2	Cable	PS5-F1-WA
												PS5-F1-WF	
	Terminals	PS5-F1-WA-VT											
		PS5-F1-WF-VT											
	Connector	PS5-F1-WA-V1											
	PS5-F1-WF-V1												
2 mm	NPN	10 to 30 Vdc	NO	200 mA	3	PS2-F2L-E							
						PS2-F2L-E2							
	PNP	20 to 250 Vac	NO	500 mA	2	PS2-F2L-A							
						PS2-F2L-A2							
AC	20 to 250 Vac	NC	500 mA	2	PS2-F2L-WA								
					PS2-F2L-WF								
5 mm	NAMUR	7 to 12 Vdc	NO+NF	-	4	Cable	PS5-F3-N/SX						
							NPN	10 to 30 Vdc	NO	200 mA	3	PS5-F3-A/SZ	
	PNP	20 to 250 Vac	NO	500 mA	2							PS5-F3-A2/SZ	
							NPN	10 to 60 Vdc	NO	100 mA	2	PS2-F4-E/SZ	
	PNP	20 to 250 Vac	NC	500 mA	2							PS2-F4-E2/SZ	
							NPN	10 to 30 Vdc	NO	200 mA	3	PS2-F5-E/SZ	
	PNP	20 to 250 Vac	NO	500 mA	2							PS2-F5-E2/SZ	
							NPN	10 to 30 Vdc	NO+NC	200 mA	4	PS2-F7-A/SZ	
	PNP	20 to 250 Vac	NO+NC	200 mA	4							PS2-F7-A2/SZ	
							NPN	10 to 30 Vdc	NO	200 mA	3	PS4-F7-A/SZ	
PNP	20 to 250 Vac	NO	500 mA	2	PS4-F7-A2/SZ								
					NPN	10 to 30 Vdc	NO	200 mA	3	PS5-F9-N4			
PNP	20 to 250 Vac	NO	500 mA	2						PS5-F9-N5			

E - Flush NE - Non-flush

Obs: Illustrative photos

Note 1: Connection diagram on page 8.

Note 1 : For detailed model dimensions, see our website www.sense.com.br Note 2: Use in areas containing combustible dust.



Non-tubular Inductive Sensors

Combustible Dust Atmosphere Certified

Q1 Line

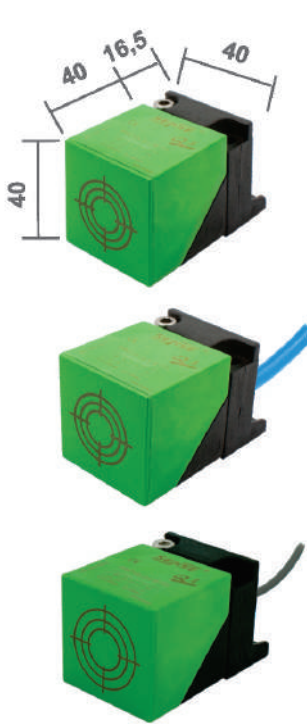

Distance	CE	Feeding	Output	Output	Mount.	Connection		Code	
20 mm	NPN	10 to 30 Vdc	NO	200 mA	E	Cable	3 wires	PS20-Q1-E	
	PNP					Connector	4 pins	PS20-Q1-E-V1	
						Cable	3 wires	PS20-Q1-E2	
30 mm	NPN	10 to 30 Vdc	NO	200 mA	NE	Connector	4 pins	PS20-Q1-E2-V1	
	PNP					Cable	2 wires	PS20-Q1-N-Ex	
						Cable	3 wires	PS30-Q1-E	
40 mm	NPN	10 to 30 Vdc	NO	200 mA	NE	Connector	4 pins	PS30-Q1-E-V1	
	PNP					Cable	3 wires	PS30-Q1-E2	
						Connector	4 pins	PS30-Q1-E2-V1	
20 mm	NPN	10 to 30 Vdc	NO	200 mA	E	Cable	2 wires	PS30-Q1-N	
	PNP					Cable	3 wires	PS40-Q1-E	
						Connector	4 pins	PS40-Q1-E-V1	
30 mm	NPN	10 to 30 Vdc	NO	200 mA	NE	Connector	4 pins	PS40-Q1-E2	
	PNP					Cable	3 wires	PS40-Q1-E2	
						Connector	4 pins	PS40-Q1-E2-V1	
40 mm	NPN	10 to 30 Vdc	NO	200 mA	NE	Cable	2 wires	PS40-Q1-N	
	PNP					Cable	4 wires	PS20-Q1-A	
						Connector	4 pins	PS20-Q1-A-V1	
20 mm	NPN	10 to 30 Vdc	NO+NC	200 mA	E	Cable	4 wires	PS20-Q1-A2	
	PNP					Connector	4 pins	PS20-Q1-A2-V1	
						Connector	4 pins	PS20-Q1-A2-V1	
30 mm	NPN	10 to 30 Vdc	NO+NC	200 mA	NE	Cable	4 wires	PS30-Q1-A	
	PNP					Connector	4 pins	PS30-Q1-A-V1	
						Connector	4 pins	PS30-Q1-A2-V1	
40 mm	NPN	10 to 30 Vdc	NO	200 mA	NE	Cable	4 wires	PS30-Q1-A2	
	PNP					Connector	4 pins	PS40-Q1-A	
						Connector	4 pins	PS40-Q1-A-V1	
20 mm	AC	20 to 250 Vac	NO	500 mA	E	Cable	2 wires	PS40-Q1-A2	
			NC					NE	PS20-Q1-WA
			NC						PS20-Q1-WF
30 mm	AC	20 to 250 Vac	NO	500 mA	NE	Cable	2 wires	PS30-Q1-WA	
			NC					PS30-Q1-WF	
			NC					PS40-Q1-WA	
40 mm	AC	20 to 250 Vac	NO	500 mA	NE	Cable	2 wires	PS40-Q1-WA	
			NC					PS40-Q1-WF	
			NC					PS40-Q1-WF	

M / M3 Line



Distance	CE	Feeding	Output	Output	Mount.	Connection		Code		
5 mm	NAMUR	7 to 12 Vdc	NC	-	E	Cable	2 wires	PS5-M-N/SX-Ex		
						Terminals	2 terminals	PS5-M-N-VT		
	NPN	10 to 30 Vdc	NO+NC	200 mA	E	Cable	4 wires	PS5-M-A		
								PS5-M-A2		
								Terminals	4 terminals	PS5-M-A-VT
								PS5-M-A2-VT		
	PNP	10 to 30 Vdc	NO+NC	200 mA	E	Connector	4 pins	PS5-M-A-V1		
								PS5-M-A2-V1		
	AC	20 to 250 Vac	NO	500 mA	E	Cable	2 wires	PS5-M-WA		
								PS5-M-WF		
Terminals								2 terminals	PS5-M-WA-VT	
PS5-M-WF-VT										
Connector								4 pins	PS5-M-WA-V1	
PS5-M-WF-V1										
2 mm	NAMUR	7 to 12 Vdc	NC	-	E	Cable	2 wires	PS2-M3-N-Ex		
	NPN	10 to 30 Vdc	NO	200 mA			3 wires	PS2-M3-E		
	PNP						PS2-M3-E2			

K1 / K7 Line



Distance	CE	Feeding	Output	Output	Mount.	Connection		Code
12 mm	NPN	10 to 30 Vdc	NO+NC	200 mA	E	Cable	4 wires	PS12-K1-A/SZ
	PNP							PS12-K1-A2/SZ
17 mm	NPN	10 to 30 Vdc	NO+NC	200 mA	NE	Cable	4 wires	PS17-K1-A/SZ
	PNP							PS17-K1-A2/SZ
12 mm	CA	20 to 250 Vac	NO	500 mA	E	Cable	2 wires	PS12-K1-WA/SY
			NC					PS12-K1-WF/SY
			NO					PS17-K1-WA/SY
			NC					PS17-K1-WF/SY
17 mm	CA	20 to 250 Vac	NO	500 mA	NE	Cable	2 wires	PS25-K7-N/SX-Ex
			NC					PS25-K7-A/SZ
25 mm	NAMUR	7 to 12 Vdc	NC	-	NE	Cable	4 wires	PS25-K7-A2/SZ
	NPN	10 to 30 Vcc	NAO+NC	200 mA				PS25-K7-WA/SY
	PNP							PS25-K7-WF/SY
	AC	20 to 250 Vac	NO	500 mA				2 wires
NC	PS25-K7-WF/SY							

Obs: Illustrative photos

E - Flush NE - Non-flush

Note 1 : For detailed model dimensions, see our website www.sense.com.br

Note 2: The connection diagrams can be found on page 8. Note 3: Use in areas containing flammable gases and vapors or combustible dust.

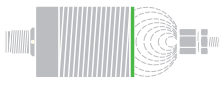

Tubular Magnetic Sensors

Combustible Dust Atmosphere Certified



PSH Line



Distance	CE	Feeding	Output	Output	Mount.	Connection		Tube Length	Code
According to Trigger	NPN	10 to 30 Vdc	NO	100 mA	E	Cable	3 wires	50 mm	PSH-12GI50-E2-Ex
	NAMUR	7 to 12 Vdc	NC	-			2 wires		PSH-18GI50-E2-Ex
	PNP	10 to 30 Vdc	NO	100 mA		Connector	4 pins		PSH-30GI50-E2-Ex
									PSH-30GI50-N-Ex
									PSH-12GI50-E2-V1-Ex
									PSH-18GI50-E2-V1-Ex
									PSH-30GI50-E2-V1-Ex

E - Flush

Sensors	Sensing Distances Table		
	MS-PSH-P	MS-XNNN	MS-PSH-G
PSH-12GI50-E2-Ex	9 mm	20 mm	36 mm
PSH-18GI50-E2-Ex	9 mm	20 mm	36 mm
PSH-30GI50-E2-Ex	9 mm	20 mm	36 mm
PSH-30GI50-N-Ex	9 mm	20 mm	36 mm

PSH Line for Pneumatic Cylinder

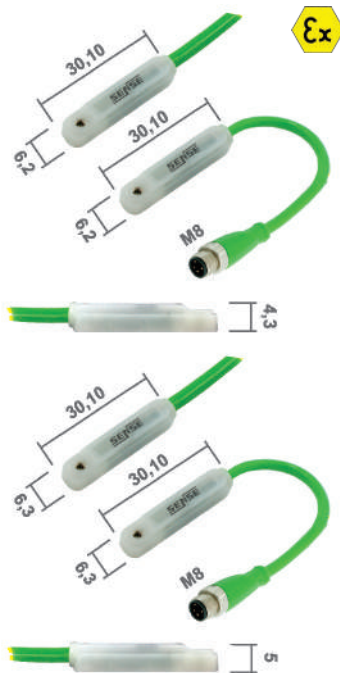

Height	CE	Feeding / Switching	Output	Output	Mount.	Connection		Code
4,3 mm	NPN	10 to 30 Vdc	NO	100 mA	T-slot Cylinder	Cable	3 wires	PSH-S6243-E-PU-Ex
			NC					PSH-S6243-E1-PU-Ex
	NO	PSH-S6243-E2-PU-Ex						
	PNP	10 to 30 Vdc	NC	100 mA		Pigtail/M8	3 pins	PSH-S6243-E3-PU-Ex
			NFC					PSH-S6243-RD-PU-Ex
	Reed	127 Vac / 170 Vdc	NO+NC	0,5 A				PSH-S6243-E-PV83
5,0 mm	NPN	10 to 30 Vdc	NO	100 mA	T-slot Cylinder	Cable	3 wires	PSH-S6243-E1-PV83
			NC					PSH-S6243-E2-PV83
	NO	PSH-S6243-E3-PV83						
	PNP	10 to 30 Vdc	NC	100 mA		Pigtail/M8	3 pins	PSH-S6243-RD-PV83
			NFC					PSH-S6350-E-PU-Ex
	Reed	127 Vac / 170 Vdc	NO+NC	0,5 A				PSH-S6350-E1-PU-Ex
5,0 mm	NPN	10 to 30 Vdc	NO	100 mA	T-slot Cylinder	Cable	3 wires	PSH-S6350-E2-PU-Ex
			NC					PSH-S6350-E3-PU-Ex
	NO	PSH-S6350-RD-PU-Ex						
	PNP	10 to 30 Vdc	NC	100 mA		Pigtail/M8	3 pins	PSH-S6350-E-PV83
			NFC					PSH-S6350-E1-PV83
	Reed	127 Vac / 170 Vdc	NO+NC	0,5 A				PSH-S6350-E2-PV83
								PSH-S6350-E3-PV83
								PSH-S6350-RD-PV83

Note 1: The sensors can be mounted on other types of cylinders with a fixing bracket.

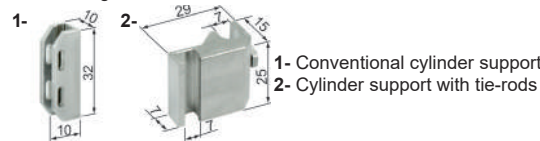

Connector M12

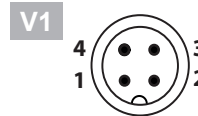

Connector M8

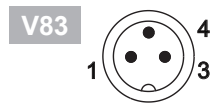

Obs: Illustrative photos

Connection Diagrams

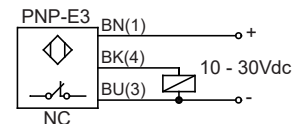
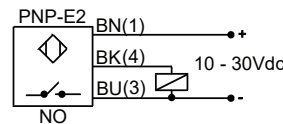
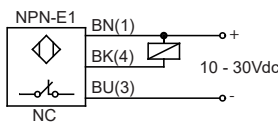
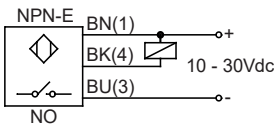
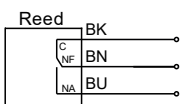

Note 2: Use in areas containing combustible dust.

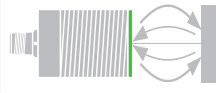

Capacitive Sensors

Gas and Combustible Dust Atmosphere Certified



M12 Capacitive Line

Ø 12 mm

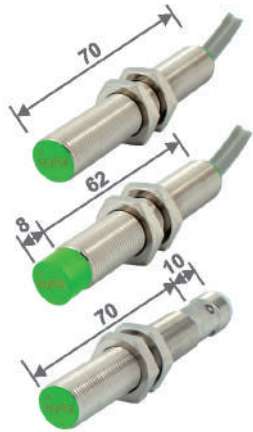

Distance	CE	Feeding	Output	Output	Mount.	Connection		Code
4 mm	NPN	10 to 30 Vdc	NO	200 mA	E	Cable	3 wires	CS4-12GI70-E-Ex
						Connector	4 pins	CS4-12GI70-E-V1-Ex
8 mm					NE	Cable	3 wires	CS8-12GI70-E-Ex
						Connector	4 pins	CS8-12GI70-E-V1-Ex
4 mm	PNP	10 to 30 Vdc	NO	200 mA	E	Cable	3 wires	CS4-12GI70-E2-Ex
						Connector	4 pins	CS4-12GI70-E2-V1-Ex
8 mm					NE	Cable	3 wires	CS8-12GI70-E2-Ex
						Connector	4 pins	CS8-12GI70-E2-V1-Ex

M18 Capacitive Line

Ø 18 mm

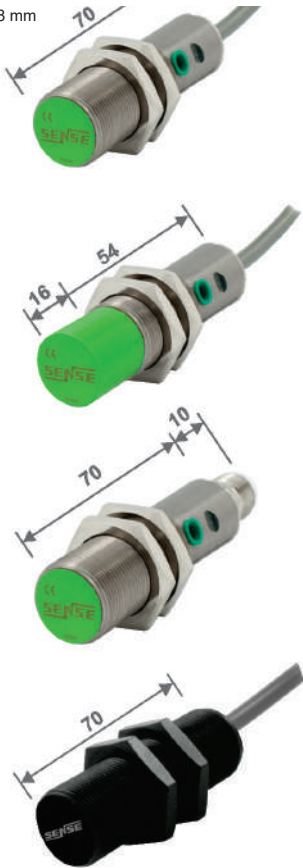

Distance	CE	Feeding	Output	Output	Mount.	Connection		Code				
5 mm	NAMUR	7 to 12 Vdc	NC	-	E	Cable	2 wires	CS5-18GI50-N-J-Ex				
						Connector	4 pins	CS5-18GI50-N-J-V1-Ex				
10 mm					NE	Cable	2 wires	CS10-18GI50-N-J-Ex				
						Connector	4 pins	CS10-18GI50-N-J-V1-Ex				
5 mm	NPN	10 to 30 Vdc	NO+NC	200 mA	E	Cable	4 wires	CS5-18GM70-A-J-Ex				
						Connector	4 pins	CS5-18GM70-A-J-V1-Ex				
10 mm					NE	Cable	4 wires	CS10-18GM70-A-J-Ex				
						Connector	4 pins	CS10-18GM70-A-J-V1-Ex				
5 mm	PNP	10 to 30 Vdc	NO+NC	200 mA	E	Cable	4 wires	CS5-18GM70-A2-J-Ex				
						Connector	4 pins	CS5-18GM70-A2-J-V1-Ex				
10 mm					NPN	10 to 30 Vdc	NO+NC	200 mA	NE	Cable	4 wires	CS10-18GM70-A2-J-Ex
										Connector	4 pins	CS10-18GM70-A2-J-V1-Ex
	PNP	10 to 30 Vdc	NO+NC	200 mA	NE	Cable	4 wires	CS10-18GP70-A-J-Ex				
						Connector	4 pins	CS10-18GP70-A-J-V1-Ex				
DC/AC	20 to 250 Vac or Vdc	NO	300 mA	NE	NE	Cable	4 wires	CS10-18GP70-A2-J-Ex				
						Connector	4 pins	CS10-18GP70-A2-J-V1-Ex				
	20 to 250 Vac or Vdc	NC	300 mA	NE	NE	Cable	2 wires	CS10-18GP70-UA-J-Ex				
						Connector	4 pins	CS10-18GP70-UA-J-V1-Ex				
20 to 250 Vac or Vdc	NC	300 mA	NE	NE	NE	Cable	2 wires	CS10-18GP70-UF-J-Ex				
						Connector	4 pins	CS10-18GP70-UF-J-V1-Ex				

E - Flush NE - Non-flush

Obs: Illustrative photos

Connection Diagram

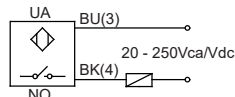
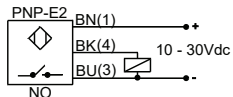
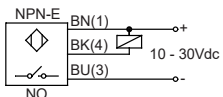
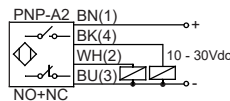
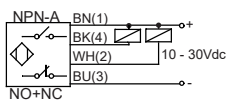
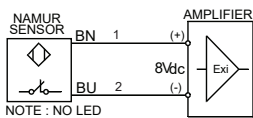

M12 Connector



V1

Types of Tubes

GI	nickel-plated brass, rear LED
GP	plastic, rear LED

Note: Use in areas containing flammable gases and vapors or combustible dust.

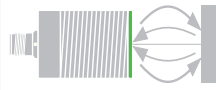

M30 and M32 Capacitive Line

Ø 30 mm

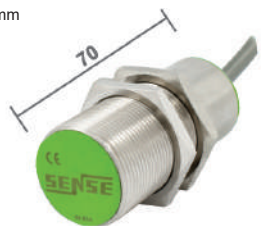

Distance	CE	Feeding	Output	Output	Mount.	Connection		Tube Length	Code						
						Cable	2 wires								
20 mm	NA-MUR	7 to 12 Vdc	NC	-	E	Cable	2 wires	50 mm	CS20-30GI50-N-J-Ex						
						Connector	4 pins		CS20-30GI50-N-J-V1-Ex						
10 mm	NPN	10 to 30 Vdc	NO+NC	200 mA		Cable	4 wires	70 mm	CS10-30GI70-A-J-Ex						
						Connector	4 pins		CS10-30GI70-A-J-V1-Ex						
20 mm	NPN				Cable	4 wires	CS20-30GI70-A-J-Ex								
					Connector	4 pins	CS20-30GI70-A-J-V1-Ex								
10 mm	PNP				Cable	4 wires	CS10-30GI70-A2-J-Ex								
					Connector	4 pins	CS10-30GI70-A2-J-V1-Ex								
20 mm	NPN				Cable	4 wires	300 mA	NE	Connector	4 pins	CS20-30GI70-A2-J-Ex				
					Cable	4 wires			CS20-30GI70-A2-J-V1-Ex						
		Connector	4 pins	CS20-30GP70-A-J-Ex											
	Cable	4 wires	CS20-30GP70-A-J-V1-Ex												
	Connector	4 pins	CS20-30GP70-A2-J-Ex												
	Connector	4 pins	CS20-30GP70-A2-J-V1-Ex												
20 mm	CC/CA	20 to 250 Vac or Vdc	NO	300 mA	Cable	2 wires	70 mm		CS20-30GP70-UA-J-Ex						
					Connector	4 pins			CS20-30GP70-UA-J-V1-Ex						
					Cable	2 wires			CS20-30GP70-UF-J-Ex						
	Connector				4 pins	CS20-30GP70-UF-J-V1-Ex									
	Cable				2 wires	50 mm			CS30-32P50-N-J-Ex						
	Connector				4 pins				CS30-32P50-N-J-V1-Ex						
30 mm	NA-MUR	7 to 12 Vdc	NC	-	NE	Cable	4 wires	70 mm	CS30-32P70-A-J-Ex						
						Connector	4 pins		CS30-32P70-A-J-V1-Ex						
						Cable	4 wires		CS30-32P70-A2-J-Ex						
	Connector					4 pins	CS30-32P70-A2-J-V1-Ex								
	Cable					2 wires	CS30-32P70-UA-J-Ex								
	Connector					4 pins	CS30-32P70-UA-J-V1-Ex								
	30 mm	NPN	10 to 30 Vdc	NO+NC		200 mA	Cable	2 wires	70 mm	CS30-32P70-UF-J-Ex					
							Connector	4 pins		CS30-32P70-UF-J-V1-Ex					
							Cable	4 wires		50 mm	CS30-Q1-A-J				
		Connector					4 pins	CS30-Q1-A-J-V1							
		50 mm					PNP	10 to 30 Vdc		NO+NC	200 mA	Cable	4 wires	70 mm	CS30-Q1-A2-J
												Connector	4 pins		CS30-Q1-A2-J-V1
50 mm	NPN	10 to 30 Vdc	NO+NC	200 mA	Terminals	4 terminals	CS50-D1-A-J								
							CS50-D1-A2-J								

E - Flush NE - Non-flush

Note: Use in areas containing flammable gases and vapors or combustible dust.

Non-tubular Capacitive Line

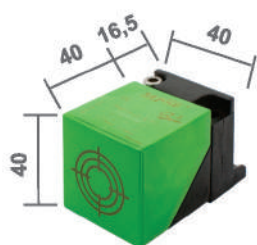

Distance	CE	Feeding	Output	Output	Mount.	Connection		Code				
						Cable	4 wires					
30 mm	NPN	10 to 30 Vdc	NO+NC	200 mA	NE	Cable	4 wires	CS30-Q1-A-J				
						Connector	4 pins	CS30-Q1-A-J-V1				
	PNP					Cable	4 wires	CS30-Q1-A2-J				
						Connector	4 pins	CS30-Q1-A2-J-V1				
50 mm	NPN					10 to 30 Vdc	NO+NC	200 mA	NE	Terminals	4 terminals	CS50-D1-A-J
												CS50-D1-A2-J

E - Flush NE - Non-flush

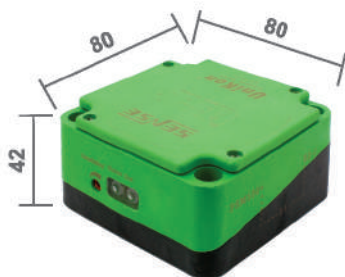

Obs: Illustrative photos

Note: The connection diagrams can be found on page 12.

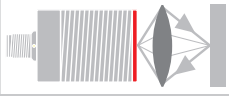

Photoelectric Tube Sensors

M18 Eco Plastic Tubular Line



Obs: No sensitivity adjustment

Type	Distance	CE	Feeding	Output	Output	Connection	Tube Length	Code
Photosensor	100 mm	NPN	10 a 30 Vdc	NC	200 mA	Cable	50 mm	OS100-18GP50-E
		PNP						OS100-18GP50-E2
	300 mm	NPN						OS300-18GP50-E
		PNP						OS300-18GP50-E2
Reflective	2 m	NPN						OR2KF-18GP50-E
		PNP						OR2KF-18GP50-E2
Barrier	20 m	NPN						TR20K-18GP50-E
		PNP						TR20K-18GP50-E2

M18 Illuminated Rear Tubular Line

Obs: Sensitivity adjustment (J)



Obs: Illustrative photos

Type	Distance	Adjust.	CE	Feeding	Output	Output	Connection	Tube Length	Code				
Photosensor	100 mm	Yes	NPN	10 to 30 Vdc	NO+NC	200 mA	Cable 4 wires	70 mm	OS100-18GI70-A-J				
							Connector 4 pins		OS100-18GI70-A-V1-J				
							Cable 4 wires		OS100-18GI70-A2-J				
							Connector 4 pins		OS100-18GI70-A2-V1-J				
							Cable 4 wires		OS300-18GI70-A-J				
							Connector 4 pins		OS300-18GI70-A-V1-J				
	50 to 300 mm	Yes	PNP	20 to 250 Vac/Vdc	L-ON D-ON	300 mA	Cable 4 wires	80 mm	OS300-18GI80-UZ3L-J				
							Connector 4 pins		OS300-18GI80-UZ3D-J				
							Cable 4 wires		OS500-18GI70-A-J				
							Connector 4 pins		OS500-18GI70-A-V1-J				
							Cable 4 wires		OS500-18GI70-A2-J				
							Connector 4 pins		OS500-18GI70-A2-V1-J				
Reflective	2 m With a polarized filter	No	NPN	10 to 30 Vdc	NO+NC	200 mA	Cable 4 wires	70 mm	OR2KF-18GI70-A				
							Connector 4 pins		OR2KF-18GI70-A-V1				
							Cable 4 wires		OR2KF-18GI70-A2				
							Connector 4 pins		OR2KF-18GI70-A2-V1				
							Cable 4 wires		OR2KF-18GI70-A-J				
							Connector 4 pins		OR2KF-18GI70-A-V1-J				
	4 m	Yes	PNP				20 to 250 Vac/Vdc		L-ON D-ON	300 mA	Cable 4 wires	80 mm	OR2KF-18GI70-A2-J
											Connector 4 pins		OR2KF-18GI70-A2-V1-J
											Cable 4 wires		OR4K-18GI70-A
											Connector 4 pins		OR4K-18GI70-A-V1
											Cable 4 wires		OR4K-18GI70-A2
											Connector 4 pins		OR4K-18GI70-A2-V1
Barrier	10 m	No	NPN	10 to 30 Vdc	NO+NC	200 mA	Cable 4 wires	70 mm	TR10-18GI70-A-J				
							Connector 4 pins		TR10-18GI70-A-V1-J				
							Cable 4 wires		TR10-18GI70-A2-J				
							Connector 4 pins		TR10-18GI70-A2-V1-J				
							Cable 4 wires		TR20-18GI70-A				
							Connector 4 pins		TR20-18GI70-A-V1				
	20 m	Yes	PNP				20 to 250 Vac/Vdc	L-ON D-ON	300 mA	Cable 4 wires	80 mm	TR20-18GI70-A2	
										Connector 4 pins		TR20-18GI70-A2-V1	
										Cable 3 wires		TR20K-18GP80-UZ3L	
										Connector 4 pins		TR20K-18GP80-UZ3L-J	
										Cable 3 wires		TR20K-18GP80-UZ3D	
										Connector 4 pins		TR20K-18GP80-UZ3D-J	

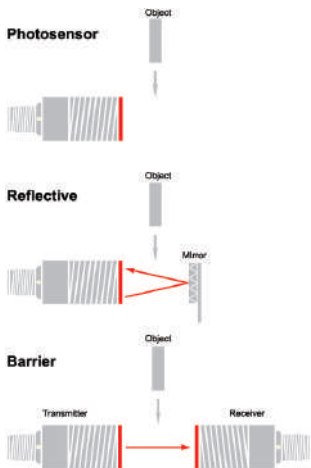

Connector M12



V1

Connection Diagram

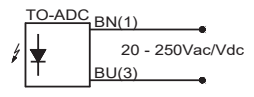
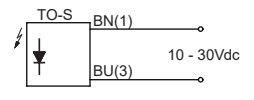
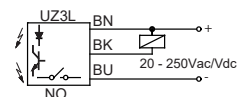
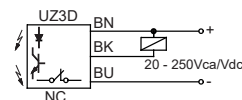
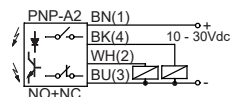
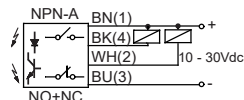
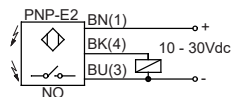
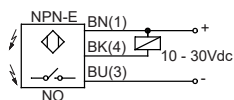

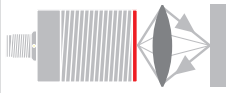

Photoelectric Tube Sensors

M18 Tubular Line



M18 Tubular Standard 90° Line

Type	Distance	Adjust.	CE	Feeding	Output	Output	Connection	Tube Length	Code	
90° Barrier	20 mm	Yes	PNP	10 to 30 Vdc	NO or NC	20 mA	Connector	4 pins	60,5 mm	C2TM-S2000CP
90° Diffuse	110 mm									C2DM-S11CP
	400 mm									C2DM-S40CP
	800 mm									C2DM-S80CP

M18 Tubular Line with Polarized Filter

Type	Distance	Adjust.	CE	Feeding	Output	Output	Connection	Tube Length	Code	
90° Barrier	0,01 to 4 m	Yes	NPN	10 to 30 Vdc	NO or NC	20 mA	Connector	4 pins	60,5 mm	C2RM-SF400CP
Straight Reflective	0,01 to 4 m		PNP				Cable			4 wires
										C2RM-SF400P

M18 Tubular Line

Type	Distance	Adjust.	CE	Feeding	Output	Output	Connection	Tube Length	Code	
BGS Diffuse Straight	300 mm	Yes	NPN	10 to 30 Vdc	NO or NC	35 mA	Connector	4 pins	60,5 mm	BGS-CM30CN
			PNP				BGS-CM30CP			
			NPN				BGS-CM30N			
			PNP				BGS-CM30P			

M18 Tubular 90° ECO Line



Type	Distance	CE	Feeding	Output	Output	Connection	Tube Length	Code	
Photosensor	100 mm	NPN	10 to 30 Vdc	NO	200 mA	Cable	4 wires	70 mm	OS100-18GPQ70-E
						Connector			OS100-18GPQ70-E-V1
						Cable			OS100-18GPQ70-E2
	300 mm	NPN				Connector			OS100-18GPQ70-E2-V1
						Cable			OS300-18GPQ70-E
						Connector			OS300-18GPQ70-E-V1
Reflective	2 m	NPN	Cable	OS300-18GPQ70-E2					
			Connector	OS300-18GPQ70-E2-V1					
			Cable	OR2KF-18GPQ70-E					
	2 m	PNP	Connector	OR2KF-18GPQ70-E-V1					
			Cable	OR2KF-18GPQ70-E2					
			Connector	OR2KF-18GPQ70-E2-V1					
Barrier	20 m	NPN	Cable	TR20K-18GPQ70-E					
			Connector	TR20K-18GPQ70-E-V1					
		PNP	Cable	TR20K-18GPQ70-E2					
			Connector	TR20K-18GPQ70-E2-V1					

M30 Standard Tubular Line



Type	Distance	Adjust.	CE	Feeding	Output	Output	Connection	Tube Length	Code						
Photosensor	1 m	Yes	NPN	10 to 30 Vdc	NO+NC	200 mA	Cable	4 wires	70 mm	OS1K-30GI70-A-J					
							Connector			OS1K-30GI70-A-V1-J					
			PNP				Cable			OS1K-30GI70-A2-J					
							Connector			OS1K-30GI70-A2-V1-J					
Reflective	6 m	No	NPN	10 to 30 Vdc	NO+NC	200 mA	Cable	3 wires	80 mm	OS1K-30GI80-UZ3L-J					
							Connector			OS1K-30GI80-UZ3D-J					
			PNP				Connector			OR6K-30GI70-A					
							Cable			OR6K-30GI70-A-V1					
Barrier	60 m	Yes	NPN	10 to 30 Vdc	NO+NC	200 mA	Connector	4 pins	70 mm	OR6K-30GI70-A2					
							Cable			OR6K-30GI70-A2-V1					
			PNP				Connector			TR60K-30GI70-A-J					
							Cable			TR60K-30GI70-A-V1-J					
			AC/DC				20 to 250 Vac or Vdc			NO/NC	300 mA	Cable	3 wires	80 mm	TR60K-30GI70-A2-J
															TR60K-30GI70-A2-V1-J
							TR60K-30GI80-UZ3L-J								
							TR60K-30GI80-UZ3D-J								

Note: The connection diagrams can be found on page 14.

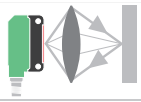

Miniature Photoelectric Sensors

CXP Line

- Diffuse, reflective or barrier models
- Non-contact magnetic adjustment
- Signal LEDs
- Recognizes output connection mode
- Prevents damage due to incorrect connection
- Facilitates field connection
- Reduce the number of parts in stock

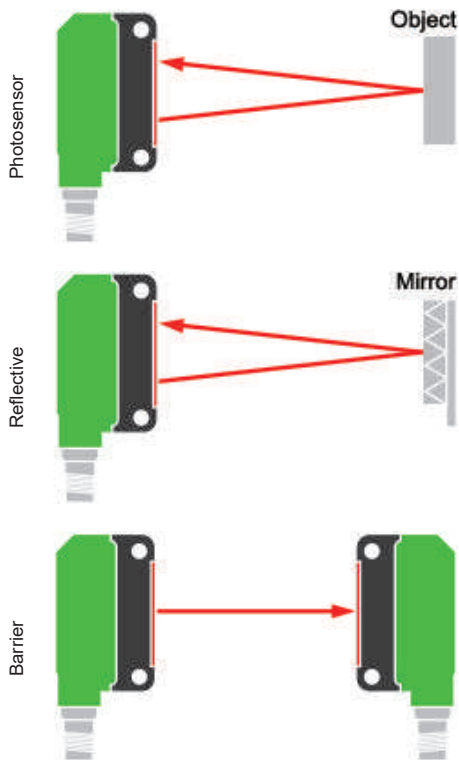
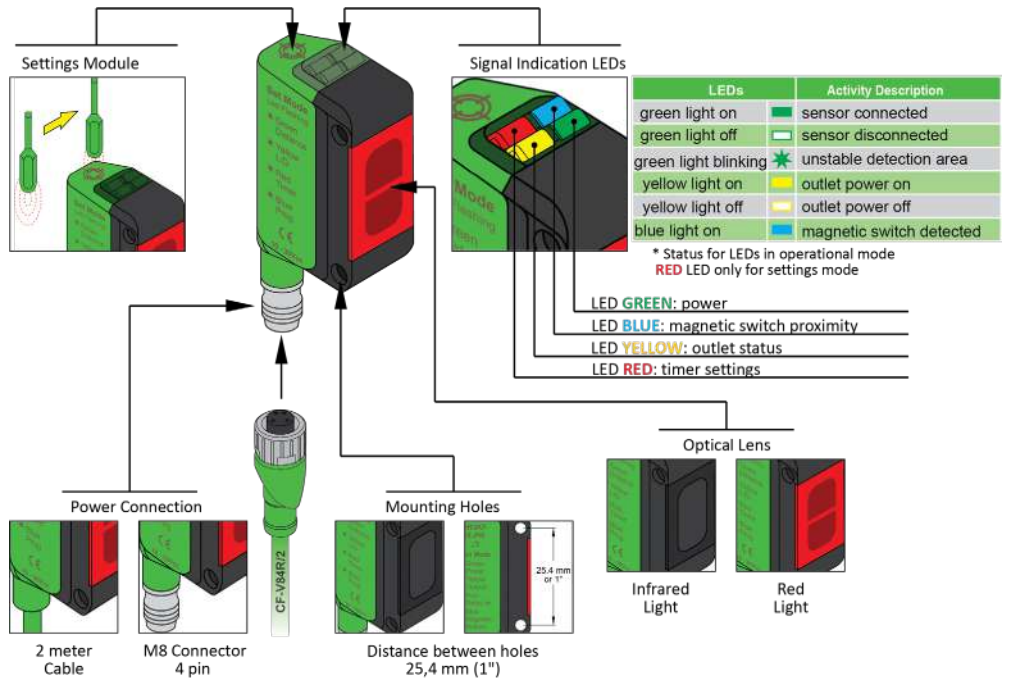

Connection Diagram

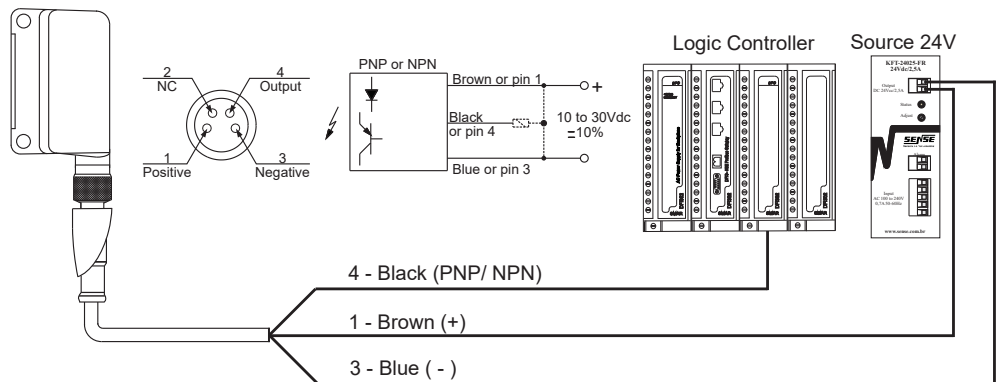

Type	Distance	CE	Feeding	Output	Connection	Code
Photosensor	32 to 300 mm	NPN/ PNP	12 to 24 Vdc	100 mA	Cable 3 wires	OS300-CXP-PN
	110 to 800 mm				Connector 4 pins	OS300-CXP-PN-V84
2000 mm					Cable 3 wires	OS800-CXP-PN
	Reflective for transparent objects				Connector 4 pins	OS800-CXP-PN-V84
3000 mm					Cable 3 wires	OR2KT-CXP-PN
	Reflective with polarized filter				7000 mm	Connector 4 pins
Barrier					15 m	Cable 3 wires
	Connector 4 pins					OR3KF-CXP-PN-V84
Barrier	25 m				Cable 3 wires	OR7KF-CXP-PN
					Connector 4 pins	OR7KF-CXP-PN-V84
Barrier	25 m	Cable 3 wires	TR15K-CXP-PN			
		Connector 4 pins	TR15K-CXP-PN-V84			
Barrier	25 m	Cable 3 wires	TR25K-CXP-PN			
		Connector 4 pins	TR25K-CXP-PN-84			

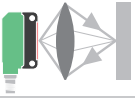

Miniature Photoelectric Sensors

BGS-Z Line



Type	Distance	CE	Feeding	Output	Connection		Code
BGS	100 mm	PNP	10 to 30 Vdc	30 mA	Connector	4 pins	BGS-Z10CP
	300 mm						BGS-Z30CP
Convergent	90 mm						ZD-L09CP
Divergent	200 mm						ZD-W20CP

BGS-ZM / Inox / IP69K Line



Type	Distance	CE	Feeding	Output	Connection		Code
BGS Diffuse	100 mm	PNP	10 to 30 Vdc	30 mA	Cable	3 wires	BGS-ZM10P
	300 mm						BGS-ZM30P
Diffuse	800 mm						ZD-M80P
Reflective	5,5 m						ZR-M550P
Barrier	30 m	ZD-M3000P					



Diagrama de Conexões

BGS-Z / ZM Line



Connector M8

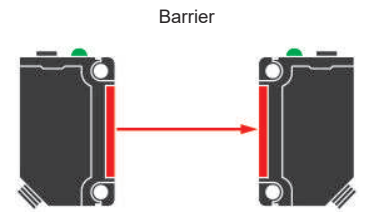
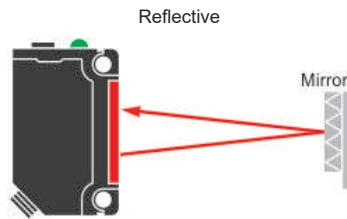
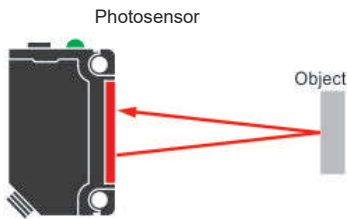
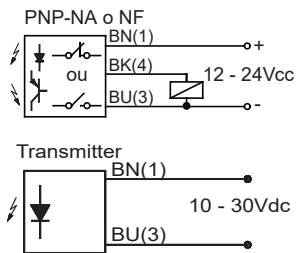
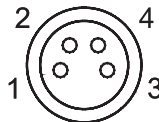

V84



Brand and Color Sensor

DM Line

- To detect any brand or color.

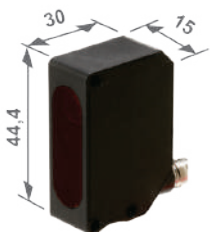

System	Distance	Feeding	CE	Output	Connection	Code
DM-18T	18 +/- 2 mm	10 to 30 Vdc	PNP	35 mA	Connector	DM-18TCP

Brand Mode



Color Mode



Non-tubular Photoelectric Sensors

EP Line

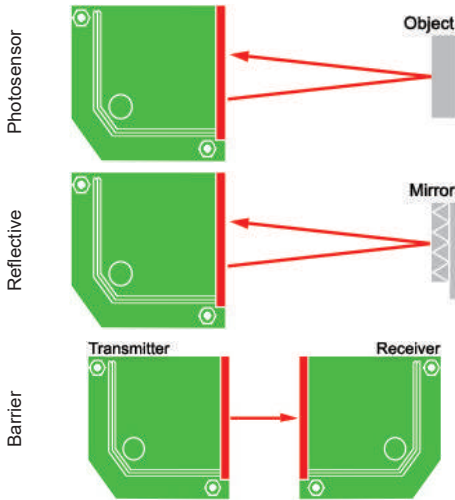
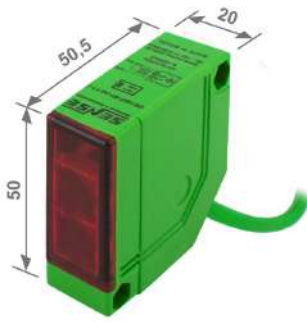

Obs: Illustrative photos

Connector M12



V1

Type	Distance	CE	Feeding	Output	Connection		Code	
Photosensor	1 m	NPN	10 to 30 Vdc	200 mA	Cable	4 wires	OS1K-EP-AL-J	
		Connector			4 pins	OS1K-EP-AL-PV1-J		
		Cable			4 wires	OS1K-EP-A2L-J		
		Connector			4 pins	OS1K-EP-A2L-PV1-J		
		Cable			4 wires	OS1K-EP-AD-J		
	Connector	4 pins	OS1K-EP-AD-PV1-J					
	Cable	4 wires	OS1K-EP-A2D-J					
	Connector	4 pins	OS1K-EP-A2D-PV1-J					
	Reflective	50 mm	NAMUR	7 to 12 Vdc	-	Cable	5 wires	OS1K-EP-RL-J
						Connector	4 pins	OS1K-EP-RD-J
1 m		NPN	10 to 30 Vdc	200 mA	Connector	4 pins	OS500-EP-N-J-Ex	
					Cable	2 wires	OR5KF-EP-N-J-Ex	
					Connector	4 pins	OR5KF-EP-N-PV1-J-Ex	
					Cable	4 wires	OR1KT-EP-AL-J	
					Connector	4 pins	OR1KT-EP-AL-PV1-J	
		Relay	10 to 250 Vdc or 12 to 240 Vac	3 A	-	Cable	4 wires	OR1KT-EP-A2L-J
						Connector	4 pins	OR1KT-EP-A2L-PV1-J
						Cable	4 wires	OR1KT-EP-AD-J
	Connector					4 pins	OR1KT-EP-AD-PV1-J	
	Cable					4 wires	OR1KT-EP-A2D-J	
Connector	4 pins	OR1KT-EP-A2D-PV1-J						
Barrier	10 m	NPN	10 to 30 Vdc	200 mA	Cable	5 wires	OR10KF-EP-RL-J	
					Connector	4 pins	OR10KF-EP-RD-J	
					Cable	4 wires	OR10KF-EP-AL-J	
					Connector	4 pins	OR10KF-EP-AL-PV1-J	
					Cable	4 wires	OR10KF-EP-A2L-J	
	Connector	4 pins	OR10KF-EP-A2L-PV1-J					
	Relay	10 to 250 Vdc or 12 to 240 Vac	3 A	-	Cable	4 wires	OR10KF-EP-AD-J	
					Connector	4 pins	OR10KF-EP-AD-PV1-J	
					Cable	4 wires	OR10KF-EP-A2D-J	
					Connector	4 pins	OR10KF-EP-A2D-PV1-J	
Cable					4 pins	OR10KF-EP-A2D-PV1-J		
Barrier	30 m	NPN	10 to 30 Vdc	200 mA	Cable	5 wires	OR10KF-EP-RL-J	
					Connector	4 pins	OR10KF-EP-RD-J	
					Cable	4 wires	TR10K-EP-N-J-Ex	
					Connector	4 pins	TR10K-EP-N-PV1-J-Ex	
					Cable	4 wires	TR10K-EP-AL-J	
	Connector	4 pins	TR10K-EP-AL-PV1-J					
	Relay	10 to 250 Vdc or 12 to 240 Vac	3 A	-	Cable	4 wires	TR10K-EP-A2L-J	
					Connector	4 pins	TR10K-EP-A2L-PV1-J	
					Cable	4 wires	TR10K-EP-AD-J	
					Connector	4 pins	TR10K-EP-AD-PV1-J	
Cable					4 wires	TR10K-EP-A2D-J		
Connector	4 pins	TR10K-EP-A2D-PV1-J						
Barrier	30 m	NPN	10 to 30 Vdc	200 mA	Cable	4 wires	TR30K-EP-AL-J	
					Connector	4 pins	TR30K-EP-AL-PV1-J	
					Cable	4 wires	TR30K-EP-A2L-J	
					Connector	4 pins	TR30K-EP-A2L-PV1-J	
					Cable	4 wires	TR30K-EP-AD-J	
	Connector	4 pins	TR30K-EP-AD-PV1-J					
	Relay	10 to 250 Vdc or 12 to 240 Vac	3 A	-	Cable	4 wires	TR30K-EP-A2D-J	
					Connector	4 pins	TR30K-EP-A2D-PV1-J	
					Cable	4 wires	TR30K-EP-RL-J	
					Connector	4 pins	TR30K-EP-RD-J	
Cable					5 wires	TR30K-EP-RD-J		

L- Light-on version D- Dark-on version

KF- Polarized filter KT- Transparent object

Connection Diagram

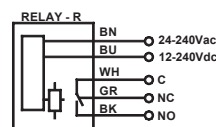
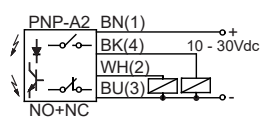
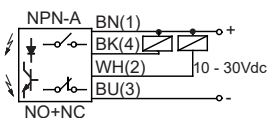



Non-tubular Photoelectric Sensors

VF Line



System	Distance	Feeding	CE	Output	Output	Connection	Code
Photosensor	1 m	10 to 30 Vdc	NPN/PNP	Transistor	200 mA	Terminal Blocks	OS1K-VF-PN-J
		12 to 240 Vdc 24 to 240 Vac	AC/DC	Timer relay	3 A		OS1K-VF-RT-J
Reflective (w/ polarized filter)	10 m	10 to 30 Vdc	NPN/PNP	Transistor	200 mA		OR10KF-VF-PN-J
		12 to 240 Vdc 24 to 240 Vac	AC/DC	Timer relay Timer relay programmable ON and OFF delay	3 A		OR10KF-VF-RT-J
Barrier (transmitter + receiver)	10 m	10 to 30 Vdc	NPN/PNP	Transistor	200 mA		TR10K-VF-PN-J
		12 to 240 Vdc 24 to 240 Vac	AC/DC	Timer relay	3 A		TR10K-VF-RT-J
	30 m	10 to 30 Vdc	NPN/PNP	Transistor	200 mA		TR30K-VF-PN-J
		12 to 240 Vdc 24 to 240 Vac	AC/DC	Timer relay	3 A		TR30K-VF-RT-J

Obs: KF- Polarized filter

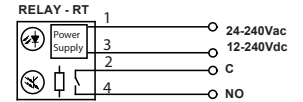
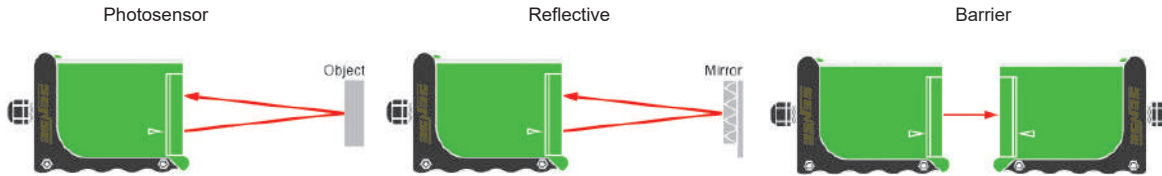
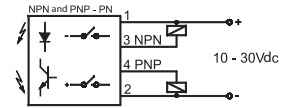

V2 Line



- Barrier models with a distance of up to 70 m.
- Models for use in harsh environments cloudy atmosphere.
- The large lenses ensure stable deection.

System	Distance	Feeding	CE	Output	Output	Connection	Code
Barrier	70 m	10 to 30 Vdc	AC/DC	Relay	3 A	Cable	V2T-7000
Reflective with polarized filter	0,01 a 12 m				2 A		V2R-1200
BGS	0,25 a 1 m						BGS-2V100

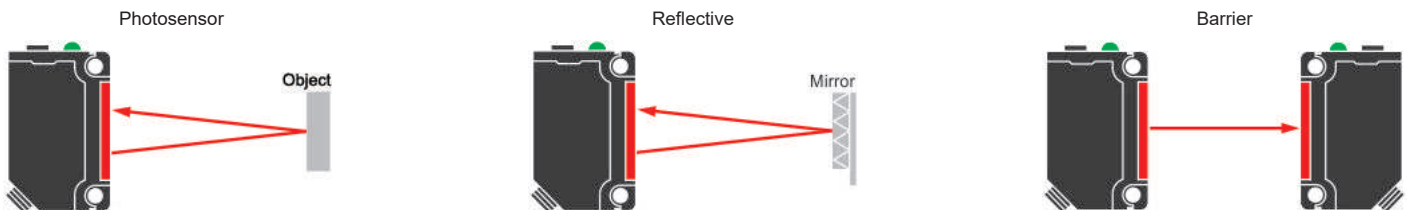

Mirrors and Tapes

Prismatic Mirror	Self-adhesive Reflective Tape		Reflective Tape for Side Fixing	Reflective Tape for Rear Fixing		
V-61	FR-530X50,8	FP-30X96	FPS-100X100	FPS-80	FPS-80R	FPS-50R

Obs: Illustrative photos



Fiber Optic Amplifiers

BRF / D1 / D3 Line



- BRF: lighth/dark adjustment by key and red light
- D1RF: distance adjustment via teach or manual with simple display
- D3RF: distance adjustment via teach or manual with dual display and red light
- D3WF: distance adjustment via teach or manual with dual display and white light
- Use with various types of fibers

Type	Indication	CE	Feeding	Output	Adjust.	Light	Connection	Code
Fiber optic amplifier	---	PNP	10 to 30 Vdc	100 mA	Pot	red	Cable	3 wires
	Simple display	PNP or NPN			Button			D3RF-T
	Double display	PNP	12 to 24 Vdc			white	4 wires	
	Double display	PNP			D3WF-TP			

Connection Diagram

BRF-P / D1RF-T / D3RF-TP

BRF / D3RF: PNP

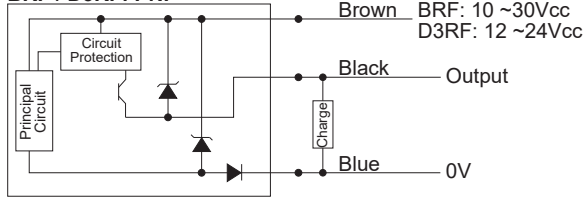

D3WF-TP

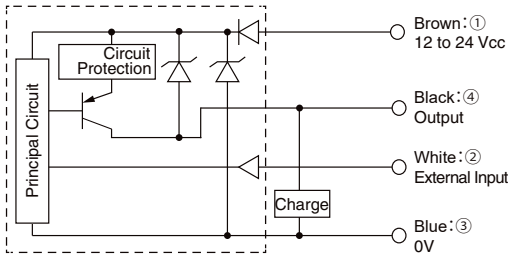

M8 Connector

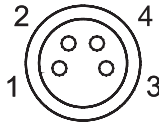

V8



Fiber Optic Cables

NF Line

Model	NF-DB01	NF-DB03	NF-DT01	NF-DB06	NF-DC09	NF-DE02	NF-DK04	NF-DM01
Fiber Optic Cables								
Nipple / Thread	5 mm / M6	3 mm / M6	M3	40 mm / M6	6x14x18 mm	2x10x10 mm	∅ 3 mm / smooth	M4
Application	general use	general use	general use	general use	general use	switchable beam	general use	general use
Distance 7-EL	1.200 mm	1.200 mm	50 mm	680 mm	0 ~ 15 mm	1.600 mm	1.200 mm	1.100 mm
Distance 6-UL	750 mm	750 mm	300 mm	630 mm	5 ~ 12 mm	150 mm	750 mm	650 mm
Distance 5-PL	650 mm	650 mm	250 mm	550 mm	5 ~ 11 mm	130 mm	650 mm	550 mm
Distance BRF	150 mm	150 mm	7 mm	10 mm	6 mm	30 mm	160 mm	160 mm
Cable	2 m	2 m	2 m	2 m	2 m	1 m	2 m	2 m

Model	NF-DS06	NF-DT02	NF-TB01	NF-TB03	NF-TB05	NF-TM02	NF-TM03	NF-TR12
Fiber Optic Cables								
Nipple / Thread	M3	15 mm / M3	3 mm / M4	90 mm / M4	40 mm / M3	5 mm / M3	∅ 1,5 mm / smooth	12x8x3 mm
Application	general use	general use	general use	general use	general use	general use	general use	general use
Distance 7-EL	400 mm	190 mm	4.000 mm	1.200 mm	270 mm	900 mm	90 mm	3.600 mm
Distance 6-UL	20 mm	125 mm	3.000 mm	750 mm	250 mm	550 mm	550 mm	3.600 mm
Distance 5-PL	190 mm	70 mm	2.200 mm	650 mm	210 mm	400 mm	400 mm	3.600 mm
Distance BRF	45 mm	10 mm	700 mm	160 mm	55 mm	120 mm	120 mm	1.300 mm
Cable	2 m	500 mm	2 m	2 m	2 m	2 m	2 m	2 m

Laser Sensors

TOF Line



Time of Flight laser sensor that measures the distance to the object by the laser's return time.
TOF-DL : Ø10 mm to 2,5 m TOF-3V: Ø12 mm to 3 m.

Type	Distance	CE	Feeding	Output	Connection		Code
Diffuse laser	0,25 to 2,5 m	Analog	12 to 30 Vdc	4 to 20 mA	Pigtail M12	5 pins	TOF-DL250AM12
		PNP/NPN	10 to 30 Vdc	100 mA			TOF-DL250TM12
	3 m	PNP	30 Vdc	70 mA			TOF-3V300CP1

Application Examples

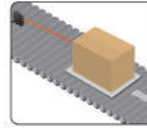

Object position on conveyors

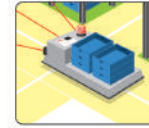

Position of automated vehicles

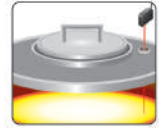

Cast aluminum level

CD22 Line

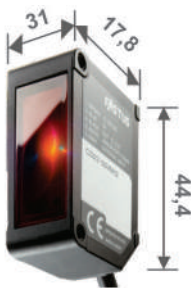

High-performance, low-cost measurement sensor in a compact housing.

Type	Distance	Output	Feeding	Output	Connection		Code
CD22	100 mm	NPN/PNP or 4 to 20mA	12 to 24 Vdc	100 mA	Cable	5 wires	CD22-100AM122
	15 mm						CD22-15AM12
	35 mm						CD22-35AM12

Application Examples

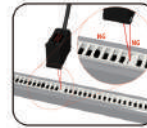

Small parts detection

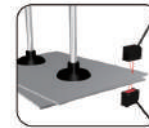

Double leaf Detection

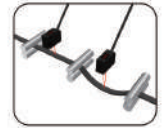

Rubber extrusion loop control

LS 2D Line



High-performance 2D measurement sensor. Connection: 2 m cable connector STL-H12-G02M

Type	Distance	CE	Feeding	Output	Connection		Code
LS-2D	100 mm	3 X PNP	12 to 24 Vdc	180 mA	Connector	14 pins	LS-100CN

Application Examples



Inspection of positioning and amount of sealant



Inspection of vehicle door openings

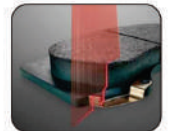

brake pad height measurement

BGS-HL Line

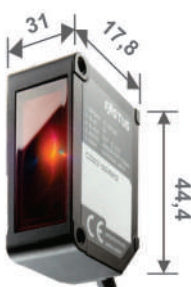

High-precision laser sensors in a compact housing.

Type	Distance	CE	Feeding	Output	Wire Number	Connection	Code
BGS-HL	20 to 50 mm	NPN/PNP	12 to 24 Vdc	100 mA	Cable	4 wires	BGS-HL05TC
	20 to 250 mm						BGS-HL25TC

Application Examples

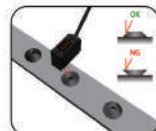

Face detection in rubber parts



Checking the camshaft position

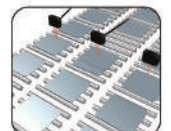

Stacked plate detection

Obs: Illustrative photos

BGS-ZL Line



Type	Distance	CE	Feeding	Output	Connection		Code
BGS Diffuse	5 to 100 mm	PNP	12 to 30 Vdc	100 mA	Connector	4 pins	BGS-ZL10CP
	10 to 300 mm						BGS-ZL30CP
Diffuse	up to 400 mm						ZD-L40CP
Reflective	up to 10 m						ZR-L1000CP
Barrier	up to 30 m						ZT-L3000CP

Application Examples



Edge Control



Object Height Control Objects

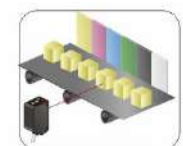

Detection without Background Interference

Note: For more information on the sensor models above and connection diagrams, see Measurement Sensors, Laser Sensors or Brand and Color Sensors on our website. www.sense.com.br

Safety Light Curtains

CLS Line



Category	Protection	Feeding	Max Distance	Beams Number	Protected Height	Controlled Height	Connection	Code
4	fingers	24 Vdc	6 m	15	160 mm	150 mm	M12 connector cable	CLS-14-160-6
				30	310 mm	300 mm		CLS-14-310-6
				45	460 mm	450 mm		CLS-14-460-6
				60	610 mm	600 mm		CLS-14-610-6
	hands		12 m	16	310 mm	300 mm		CLS-24-310-12
				23	460 mm	450 mm		CLS-24-460-12
				31	610 mm	600 mm		CLS-24-610-12
				38	760 mm	750 mm		CLS-24-760-12
				46	910 mm	900 mm		CLS-24-910-12
				53	1060 mm	1050 mm		CLS-24-1060-12
				61	1210 mm	1200 mm		CLS-24-1210-12
				68	1360 mm	1350 mm		CLS-24-1360-12
	access control		12 m	76	1510 mm	1500 mm		CLS-24-1510-12
				2	510 mm	590 mm		CLS-34-510-12
				2	510 mm	590 mm		CLS-34-510-20
				3	810 mm	890 mm		CLS-34-810-12
				3	810 mm	890 mm		CLS-34-810-20
				4	910 mm	990 mm		CLS-34-910-12
				4	910 mm	990 mm		CLS-34-910-20

Fixing brackets

Safety Relays



Feeding	Security Level	Response Time	Connection	Outputs Number	Signaling LEDs	Fixing	Code
24 Vdc	PL e - Cat. 4	≤ 20 ms	plug-in terminals	2NO - 2A@250Vac	no	rail DIN 35 mm	RS-2A
				2NO+1NC - 2A@250Vac			RS-2A1F
	SILCL 3 - PL e - Cat. 4			yes	RS1-2A		

Safety Connectors



Version	Type	Contact Number	Cable Output	Fixing Thread	Cable Length	Code
connector with cable	female	5	straight	M12	5 m	CFS-V15R/5
					10 m	CFS-V15R/10
					15 m	CFS-V15R/15
		8			5 m	CFS-V18R/5
					10 m	CFS-V18R/10
					15m	CFS-V18R/15

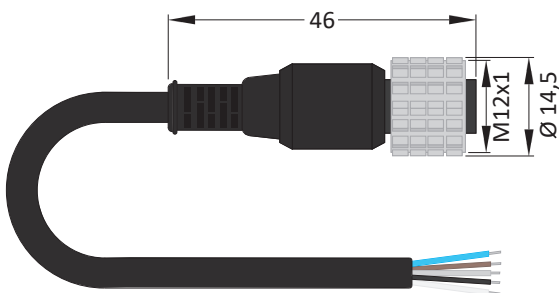

5 Pins Connector

8 Pins Connector

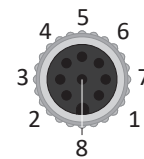
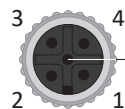

- 1 - Brown
- 2 - White
- 3 - Blue
- 4 - Black
- 5 - Gray

- 1 - White
- 2 - Brown
- 3 - Green
- 4 - Yellow
- 5 - Gray
- 6 - Pink
- 7 - Blue
- 8 - Red

Note: For more information on the above models and connection diagrams, see Human Protective Devices on our website www.sense.com.br

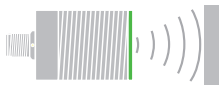

Standard Line



Max Distance	Dia.	Output Prog.	Digital Output	Analog Output	Output	Feeding	Connection	Code
100 mm	8 mm	NO or NC	PNP, NPN or Push-Pull	-	150 mA	12 - 30 Vdc	Connector M8 - 4p	US100-8GI50-IO
400 mm	12 mm	NO or NC	PNP, NPN or Push-Pull	-			US400-12GI50-IO	
1500 mm	18 mm	NO or NC	PNP, NPN or Push-Pull	-			US1500-18GI50-IO	
3000 mm	30 mm	NO or NC	PNP, NPN or Push-Pull	-	100 mA		Connector M12-4p	US3000-30GI50-IO
6000 mm		NO or NC	PNP, NPN or Push-Pull	-			US6000-30GI50-IO	
400 mm	12 mm	NO or NC	PNP, NPN or Push-Pull	0 - 20 or 4-20 mA or 0 - 10 V	150 mA		Connector M12-4p	US400-12GI50-AN
1500 mm	18 mm	NO or NC	PNP, NPN or Push-Pull	0 - 20 or 4-20 mA or 0 - 10 V				US1500-18GI50-AN
3000 mm	30 mm	NO or NC	PNP, NPN or Push-Pull	0 - 20 or 4-20 mA or 0 - 10 V				100 mA
6000 mm		NO or NC	PNP, NPN or Push-Pull	0 - 20 or 4-20 mA or 0 - 10 V	US6000-30GI50-AN			

Note: Configuring the digital output on -AN models is only done via IO-Link.

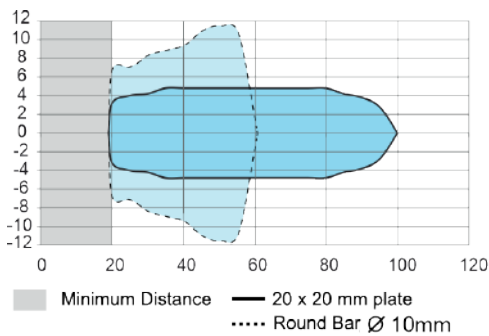
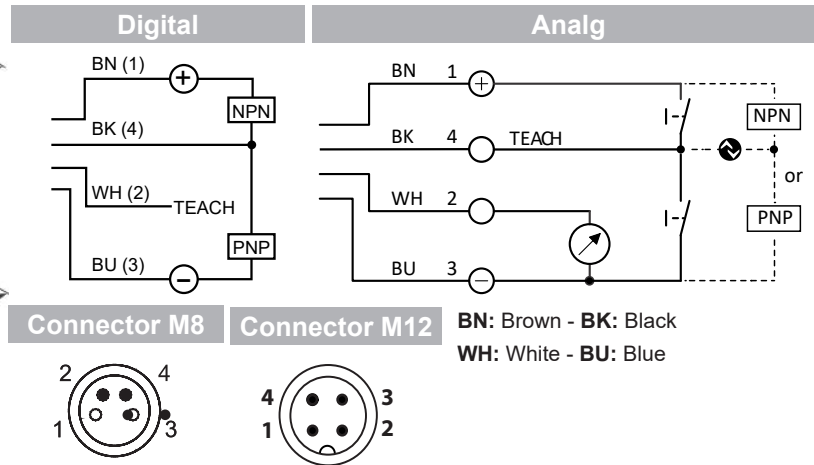

US100 Graphic

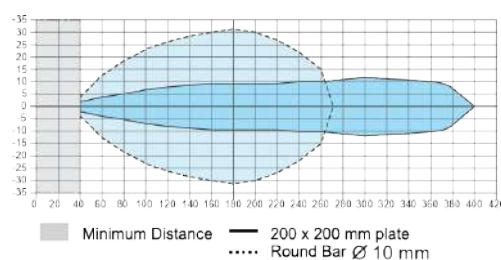

US400 Graphic

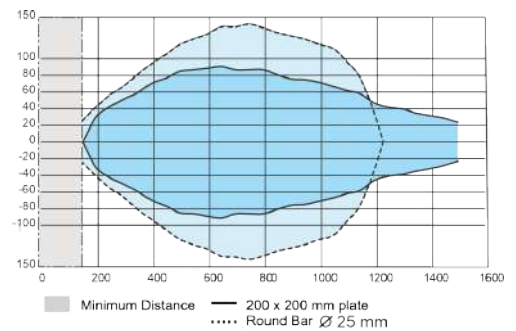

US1500 Graphic

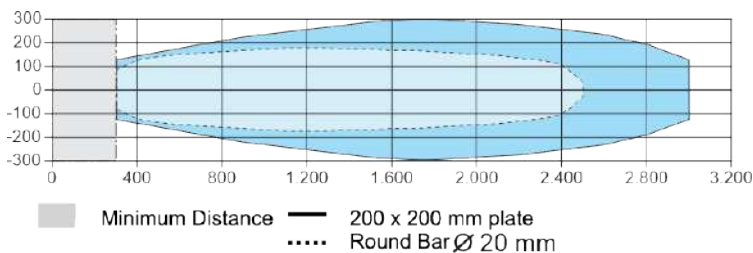

US3000 Graphic

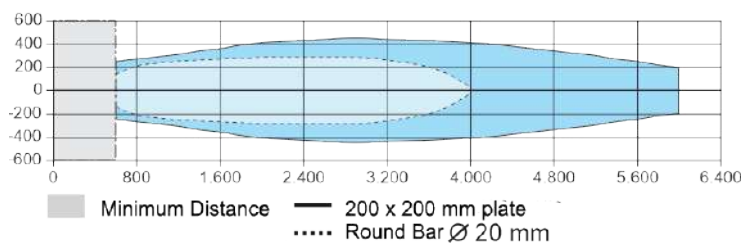

US6000 Graphic

Ultrasonic Sensors

US4.Smart Line

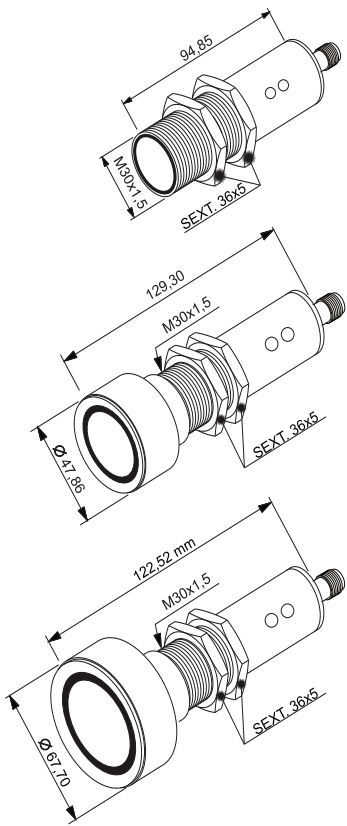

Max Distance	Output Prog.	Digital Output	Analog Output	Output	Feeding	Connection	Code	
1300 mm	NO or NC	PNP / NPN	-	200 mA	18 - 30 Vdc	Cable 2 m	4 wires	US4.1300-30GX98-PN
	-	-	4 - 20 mA 0 - 20 mA	-		Connector	4 pins	US4.1300-30GX98-PN-V1
3400 mm	NO or NC	PNP / NPN	-	200 mA		Cable 2 m	4 wires	US4.1300-30GX98-AN
	-	-	4 - 20 mA 0 - 20 mA	-		Connector	4 pins	US4.1300-30GX98-AN-V1
6000 mm	NO or NC	PNP / NPN	-	200 mA		Cable 2 m	4 wires	US4.3400-30GX98-PN
	-	-	4 - 20 mA 0 - 20 mA	-		Connector	4 pins	US4.3400-30GX98-PN-V1
	NO or NC	PNP / NPN	-	200 mA		Cable 2 m	4 wires	US4.3400-30GX98-AN
	-	-	4 - 20 mA 0 - 20 mA	-		Connector	4 pins	US4.3400-30GX98-AN-V1
	NO or NC	PNP / NPN	-	200 mA		Cable 2 m	4 wires	US4.6000-30GX98-PN
	-	-	4 - 20 mA 0 - 20 mA	-		Connector	4 pins	US4.6000-30GX98-PN-V1
	NO or NC	PNP / NPN	-	200 mA		Cable 2 m	4 wires	US4.6000-30GX98-AN
	-	-	4 - 20 mA 0 - 20 mA	-		Connector	4 pins	US4.6000-30GX98-AN-V1

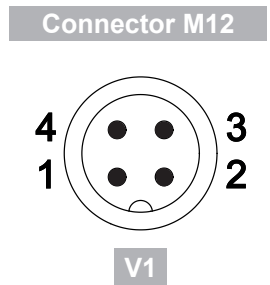
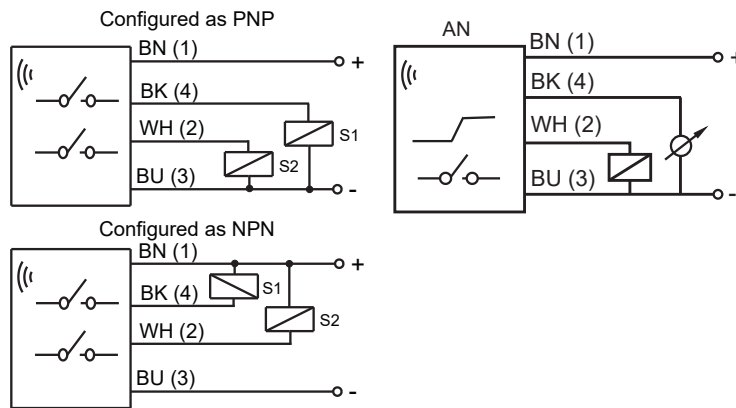

Configuration via App

In addition to configuring the outputs via the magnetic switch, other more complex sensor functions are configured via an app with a simple, user-friendly interface available for smartphones with Android or iOS operating systems. The sensors are connected via Bluetooth technology.

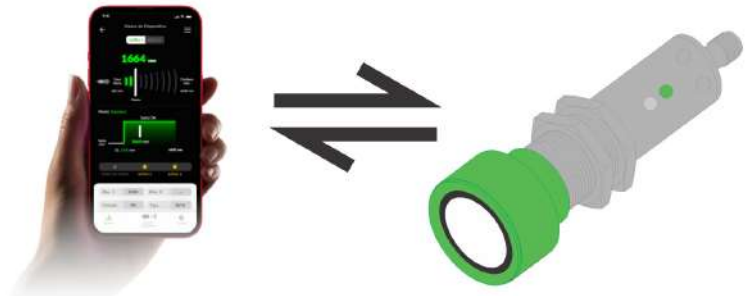

Application Screenshots

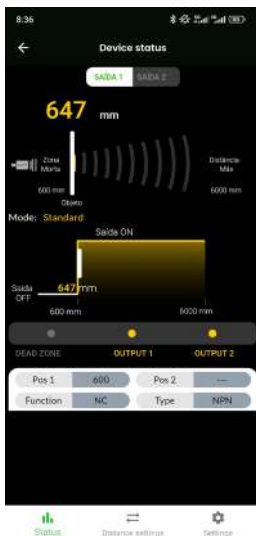

Status Screen

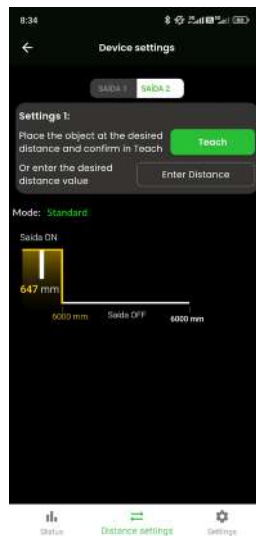

Distance Adjustment Screen

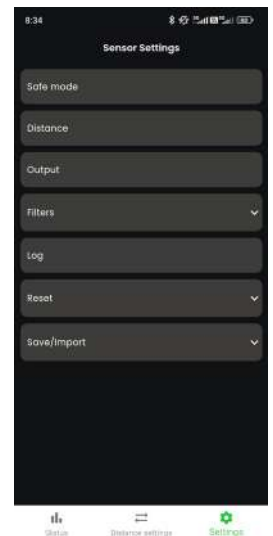

Settings Screen



Ultrasonic Sensors

US1300 Line



Max Distance	Output Prog.	Digital Output	Analog Output	Output	Feeding	Connection	Code	
1300 mm	NO or NC	double PNP	-	200 mA	12 - 30 Vdc	Cable 2 m	4 wires	US1300-30GX98-2E2-J
						Connector	4 pins	US1300-30GX98-2E2-J-V1
	-	-	4 - 20 mA	-		Cable 2 m	4 wires	US1300-30GX98-AN-J
						Connector	4 pins	US1300-30GX98-AN-J-V1

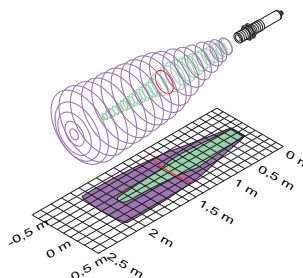
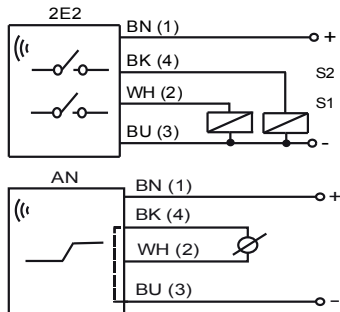

Connector M12

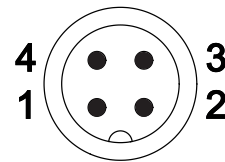

V1

Nominal sensing distance: 1100 mm (adjustable). Dead zone: 300 mm.

Mic + Line



Max Distance	Dia.	Output Prog.	Digital Output	Analog Output	Output	Feeding	Connection	Code
250 mm	30 mm	NO or NC	PNP	-	200 mA			MIC+25/D/TC
			double PNP					MIC+25/DD/TC
		-	-	0 to 10 V or 4-20 mA or PNP				MIC+25/IU/TC
								NO or NC
350 mm	47,5 mm	-	-	0 to 10 V or 4-20 mA or PNP				MIC+35/D/TC
								double PNP
		-	-	0 to 10 V or 4-20 mA or PNP				MIC+35/IU/TC
								NO or NC
1300 mm		-	-	0 to 10 V or 4-20 mA or PNP		9 - 30 Vdc	Connector 5 pins	MIC+130/D/TC
								double PNP
		-	-	0 to 10 V or 4-20 mA or PNP				MIC+130/IU/TC
								NO or NC
3400 mm		-	-	0 to 10 V or 4-20 mA or PNP				MIC+340/D/TC
								double PNP
		-	-	0 to 10 V or 4-20 mA or PNP				MIC+340/IU/TC
								NO or NC
6000 mm		-	-	0 to 10 V or 4-20 mA or PNP				MIC+600/D/TC
								double PNP
		-	-	0 to 10 V or 4-20 mA or PNP				MIC+600/IU/TC
								NO or NC

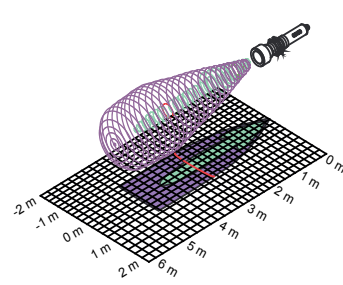
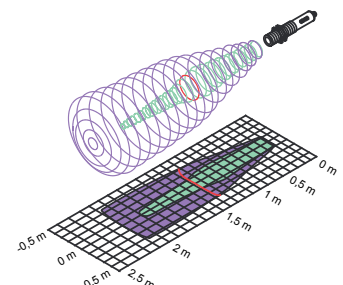
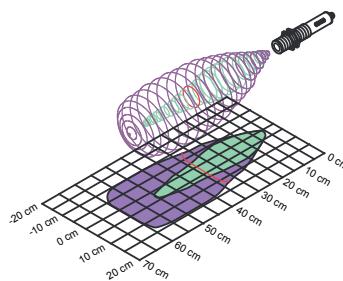
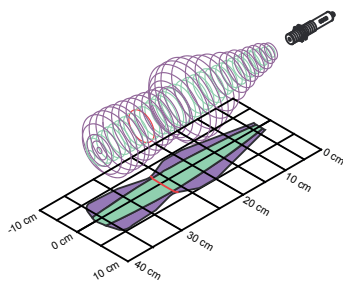
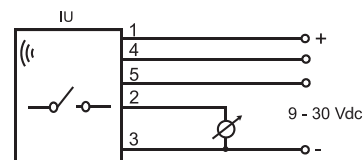
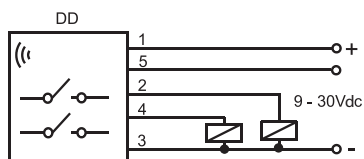
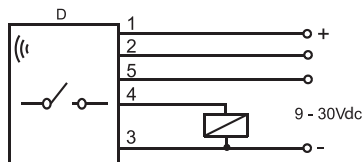

M12 Connector / 5 pins

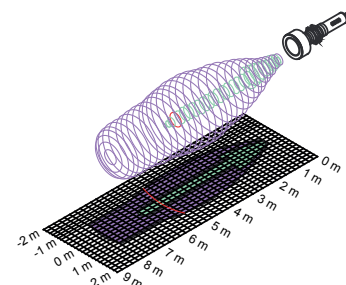
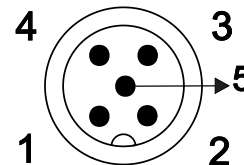



Tubular Speed Monitor



The Speed Monitor operates in under or over speed and stop detection for ranges up to 6,000 rpm. It has an initial timer with an energization delay and a maximum switching frequency of 100Hz.

- 3 in 1: under speed, over speed and stop detection
- Fully sealed construction
- High-visibility LED indicator
- Application in areas with combustible dust
- Marking: Ex ma IIC T6 Ga IP66/IP67
Ex ma IIIC T200 95°C Da IP66/IP67

Model	Type	Distance	Output	Output Configuration	Configuration
PS5-18GX90-MA2-Ex	Inductive	5 mm	2x PNP	NO or NC	Magnetic Key

Magnetic Fixing Bracket for Tubular Speed Monitor



SUPP is a mounting and protection bracket with metal targets for use with the tubular speed monitor. The monitor is mounted on the bracket and the assembly attaches to the shaft of the monitored equipment via a direct thread or a magnetic adapter.

Vibrations do not affect the operation of the monitor, as it moves along with the monitored shaft.

- Use with tubular speed monitor
- M18 hole for monitor mounting
- Easy and safe installation
- Mounted directly on the monitored axis
- Magnetic adapter to simplify assembly
- Not affected by axial or machine vibrations

Model	Function	Target Number	Sensor Connection	Conduit Connection	Shaft Fixing
SUPP-4C	support with metal targets	4	M18x1	polycarbonate glove	high efficiency magnet
SUPP-6C		6			
SUPP-8C		8			

Bearing Temperature Sensor

These are temperature sensors specially designed to be installed in engine bearings. The sensors have a grease nipple to lubricate the bearing without having to remove the sensor.



Model	Bearing Type	Sensor Type	Wires Number	Grease Nipple
SM-103-0...	no protection NR12	Pt-100	3 wires	yes
SM-104-0...			4 wires	
SM-TM-0...		thermostat	2 wires	
SM-103-NR...	protected NR12	Pt-100	3 wires	
SM-104-NR...			4 wires	
SM-TM-NR...		thermostat	2 wires	

Belt Misalignment Sensor

These are temperature or contact sensors connected to sacrificial plates, which detect misalignment problems in elevators and belt conveyors. When a belt is misaligned or a pulley moves against the plate, the system temperature rises and the sensor sends a signal to the PLC (temperature sensor) or opens the contact (NC thermostat).



Model	Sensor Type	Wire Number	Sacrifice Plate
SD-103...	Pt-100	3 wires	round square or rectangular
SD-104...		4 wires	
SD-TM...	thermostat	2 wires	

Sacrifice Plate

These are plates connected to temperature sensors for detecting misalignment of pulleys and belts in elevators and conveyors.

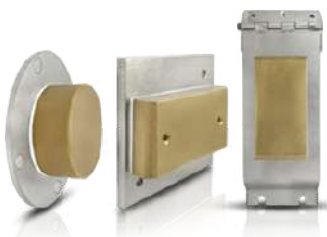

Model	Form	Hinge	Utilization
PS-RD-86	round	no	belt misalignment sensors
PS-RT-D-100x50	rectangular	yes	
PS-QD-110	square	no	

Note: Temperature transmitter available for SM and SD models that use a Pt-100 thermoresistor. Consult our Applications Engineering.



Connectors

Type	Model	Mechanical Design (mm)	Applic.	Connec.	Thread	Code	Hitch			
M12 Connectors for Sensors, I/O Network Module, DN, DP			AC/DC	4 pins	Plastic	PL-V1AP	Female / straight			
			I/O	4 pins		PLM-V1AP	Male / straight			
			DN/DP	5 pins		PLM-V15AP	Male / straight			
			AC/DC	4 pins		PL-V1AM	Female / straight			
			I/O	4 pins	Metallic	PLM-V1AM	Male / straight			
			DN/DP	5 pins		PLM-V15AM	Male / straight			
			M12 Connectors with Cable for DC/PNP/NPN Sensors			CC/CA	4 pins	Plastic	PL-V1BP	Female / 90°
						I/O	4 pins		PLM-V1BP	Male / 90°
						DN/DP	5 pins		PLM-V15BP	Male / 90°
						AC/DC	4 pins	Metallic	PL-V1BM	Female / 90°
I/O	4 pins	PLM-V1BM				Male / 90°				
DN/DP	5 pins	PLM-V15BM				Male / 90°				
M12 Connectors for Sensors			AC/DC	4 pins	Metallic	CF-V1R/VT	Female / straight			
						CF-V190/VT	Female / 90°			
						CM-V1R/VT	Male / reto			
						CM-V190/VT	Male / 90°			

Type	Model	Mechanical Design (mm)	Aplicc.	Connec.	Thread	Code	Hitch
M8 Mountable Connectors			DC	3 pins	Metallic	PL-V83B	Female / 90°
				4 pins		PL-V83A	Female / straight
				3 pins		PL-V84B	Female / 90°
						PL-V84A	Female / straight
M8 Connectors for Sensors with Injected Cables			PNP	4 pins	Metallic	CF-V83R/2PU	Female / 90°
						CF-V8390/2PU	Female / 90°
						CF-V84R/2PU	Female / straight
						CF-V8490/2PU	Female / 90°
M8 Connector PNP / NPN Converter			PNP/NPN	4 pins	Metallic	CFN-V8490/2PU	Female / 90°
						CFN-V8490/2PNP	Female / 90°

Obs: 2N: 2 leds NPN - 2P: 2 leds PNP - PU: Polyurethane

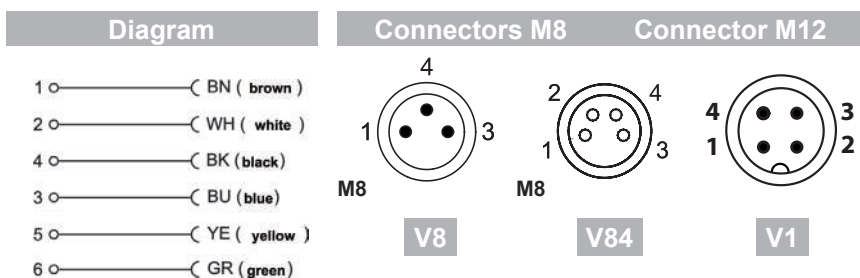

Network Connectors

Sense also offers industrial network connectors, power connectors, expansion connectors and connectors for I/O modules. See the available models below.





Connectors

Type	Model	Mechanical Design (mm)	Applic.	Connecc.	Code	Hitch	
M12 Connectors for CC/CA NPN/PNP Sensors			AC/DC	4 pins	CM-V1R/2PU	Male / straight	
				5 pins	CM-V15R/2PU		
				4 pins	CF-V1R/2PU	Female / straight	
				5 pins	CF-V15R/2PU		
						3 pins	CF-V1390/2
	4 pins	CM-V190/2PU				Male 90°	
		CF-V190/2PU				Female 90°	
	5 pins	CF-V1590/2PU				Male 90°	
		CM-V1590/2PU					
	M12 Connectors for CC Sensors - NPN/PNP LED Illuminated Version				PNP	3 pins	CFP-V1390/2
NPN			CFN-V1390/2				
PNP			4 pins		CFP-V190/2PU	Male 90°	
NPN					CFN-V190/2PU		
PNP			5 pins		CMP-V190/2PU	Female 90°	
NPN					CMN-V190/2PU		
5 pins			5 pins		CFP-V1590/2PU	Male 90°	
					CFN-V1590/2PU		
5 pins			5 pins		CMP-V1590/2PU	Female 90°	
					CMN-V1590/2PU		
Extension with M12 Connectors - General Use			AC/DC	4 pins	CF-V1R/2PU/CM-V1R Female (straight) / Male (straight)		
				5 pins	CF-V15R/2PU/CM-V15R Female (straight) / Male (straight)		
				6 pins	CF-V16R/2PU/CM-V116R Female (straight) / Male (straight)		
				4 pins	CF-V190/2PU/CM-V1R Female (straight) / Male (90°)		

New 7/8" Connector

7/8" Diagram and Pinout

Straight Connector Safety Lock

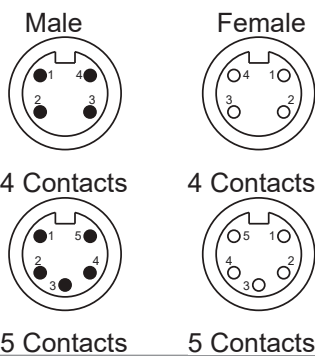

7/8" lock



CP-VM



Tubular Sensor Support

The mounting bracket is robust and suitable for mounting tubular sensors.

- Made of 304 stainless steel for M8, M12, M18 and M30 tubular sensors
- Fixing with M5x1 screws included



MS-08



MS-12



MS-18









MS-30

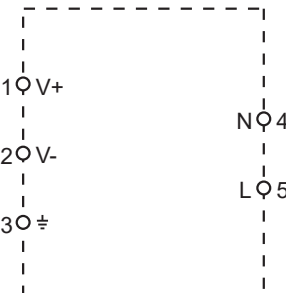
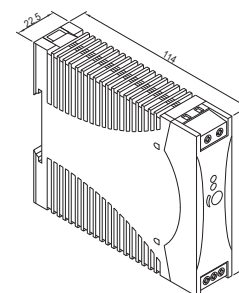

Instruments

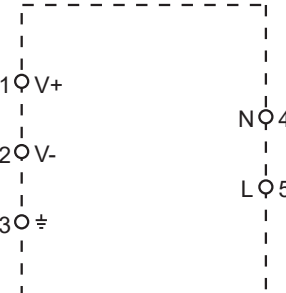
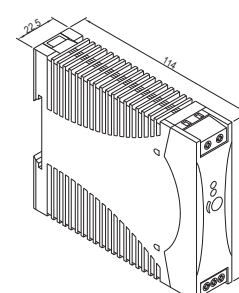
Switch-mode power supplies can be supplied with 5Vdc, 12Vdc or 24Vdc outputs, including three-phase models. They are available with power ratings from 18W to 480W. They feature high efficiency, internal short-circuit protection circuitry, compact housing and DIN rail mounting. They are ideal for use in industrial environments.

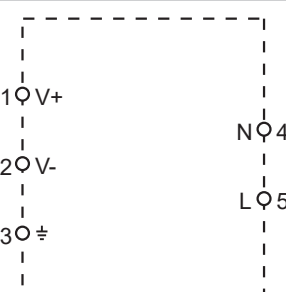
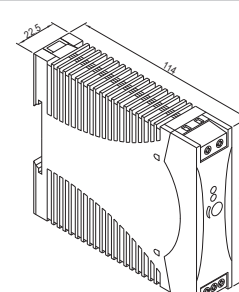

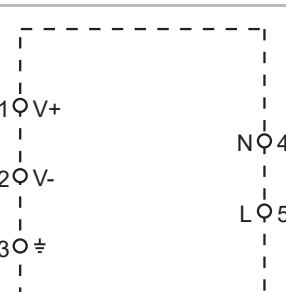
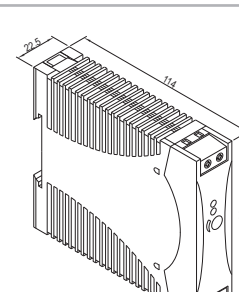



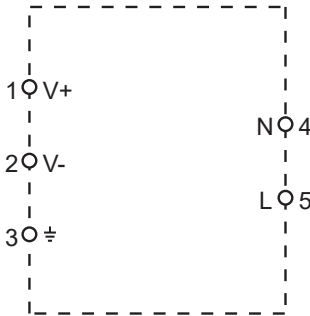
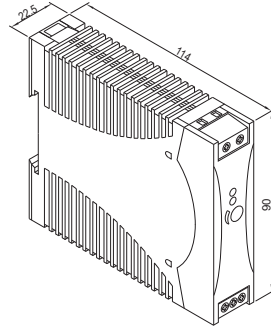

Power Supplies

Code	Model	Connection Diagram	Mechanical Design (mm)	Voltage/ Output Current
KFG-0501/ 110-220 Vca				5 Vdc / 1A
KFG-0502/ 110-220 Vca				5 Vdc / 2A
KFG-0503/ 110-220 Vca				5 Vdc / 3A
KFG-12004/ 110-220 Vca				5 Vdc / 0,42A

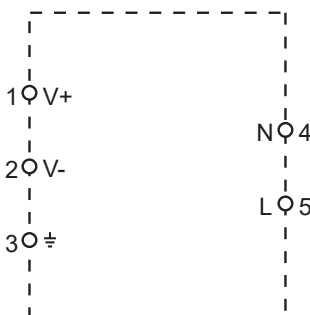
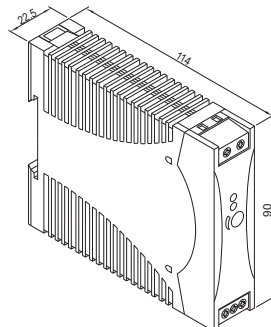

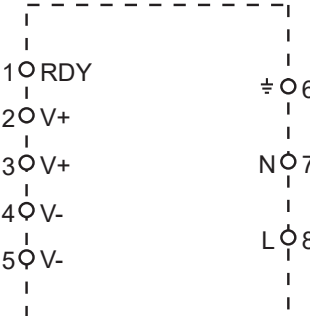
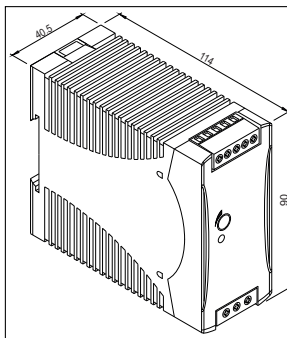
Instruments

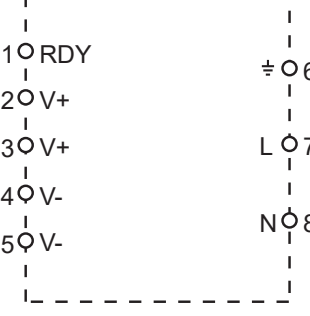
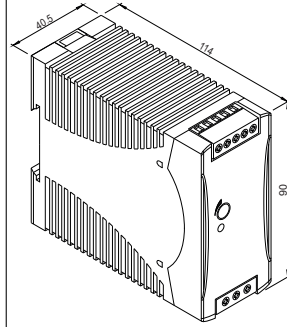
Power Supplies

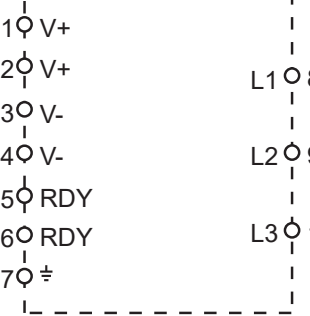
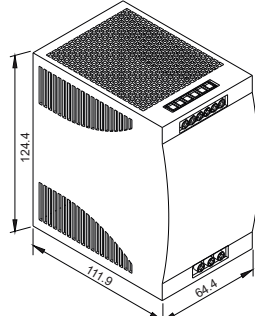





Code	Model	Connection Diagram	Mechanical Design (mm)	Voltage/ Output Current
KFG-12008/ 110-220 Vca		 <pre> 1 1V+ 2 2V- 3 0≐ NO 4 LO 5 </pre>		12 Vdc / 0,8A
KFG-12015/ 110-220 Vca		 <pre> 1 1V+ 2 2V- 3 0≐ NO 4 LO 5 </pre>		24 Vdc / 1,5A
KFG-12025/ 110-220 Vca		 <pre> 1 0RDY 2 1V+ 3 3V+ 4 2V- 5 3V- ≐ 6 NO 7 LO 8 </pre>		12 Vdc / 2,5A
KFG-1205/ 110-220 Vca		 <pre> 1 0RDY 2 1V+ 3 3V+ 4 2V- 5 3V- ≐ 6 LO 7 NO 8 </pre>		12 Vdc / 5A
KFG-1210/ 110-220 Vca		 <pre> 1 1V+ 2 2V+ 3 3V- 4 4V- 5 0RDY 6 0RDY 7 0≐ L1 8 L2 9 L3 10 </pre>		12 Vdc / 10A

Note: RDY is a normally open contact used to alarm the DC voltage level.

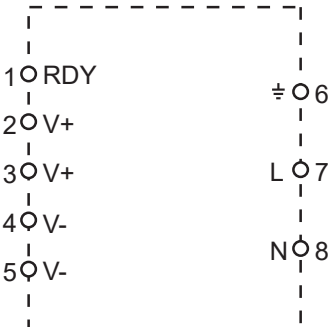
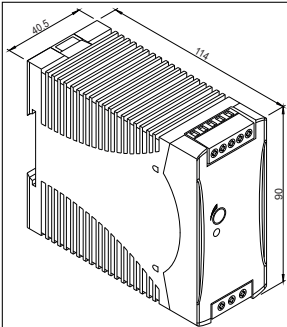

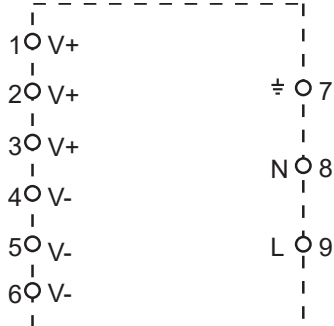
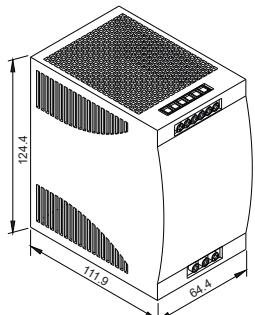
Instruments

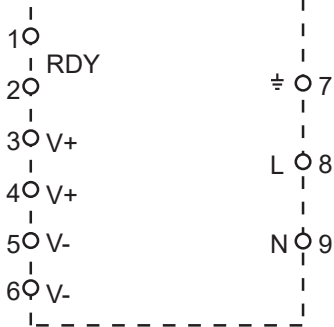
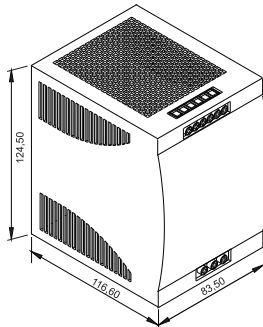
Power Supplies

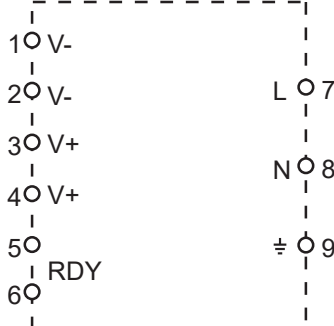
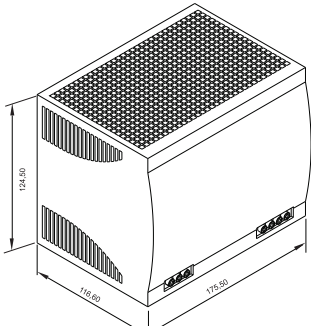



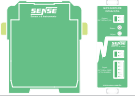

Code	Model	Connection Diagram	Mechanical Design (mm)	Voltage/ Output Current
KFG-24025/ 110-220 Vca		 <p>1 RDY 2 V+ 3 V+ 4 V- 5 V-</p> <p>≡ O 6 L O 7 N O 8</p>		24 Vdc / 2,5A
KFG-2405/AT 110-220 Vca		 <p>1 V+ 2 V+ 3 V+ 4 V- 5 V- 6 V-</p> <p>≡ O 7 N O 8 L O 9</p>		24 Vdc / 5A
KFG-2410R/AT 110-220 Vca		 <p>1 RDY 2 V+ 3 V+ 4 V+ 5 V- 6 V-</p> <p>≡ O 7 L O 8 N O 9</p>		24 Vdc / 10A
KFG-2420R/AT 110-220 Vca		 <p>1 V- 2 V- 3 V+ 4 V+ 5 RDY 6 V-</p> <p>L O 7 N O 8 ≡ O 9</p>		24 Vdc / 20A

Nota: RDY is a normally open contact used to alarm the DC voltage level.

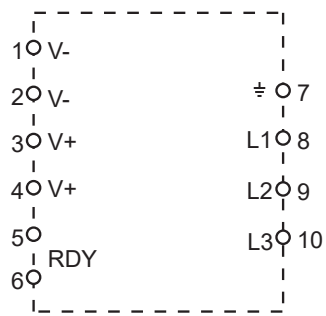
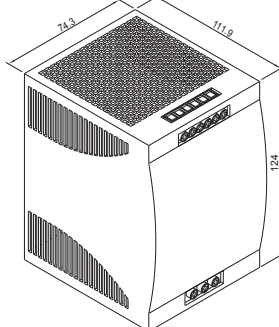

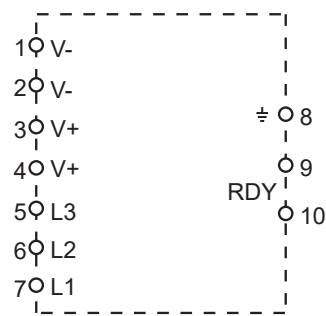
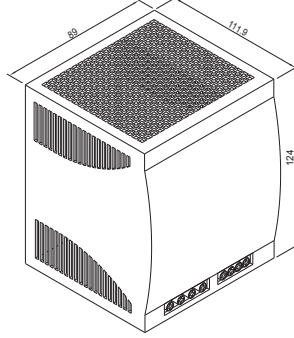
Instruments

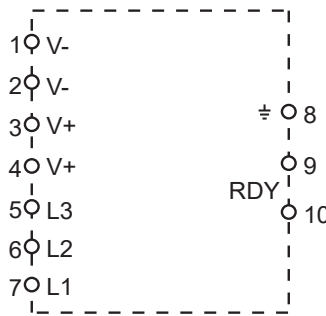
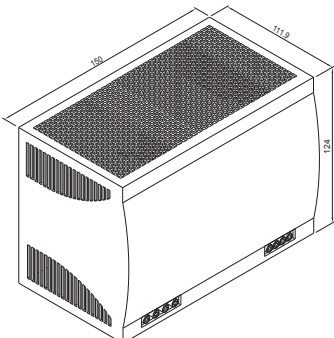

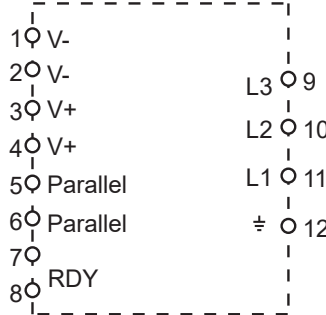
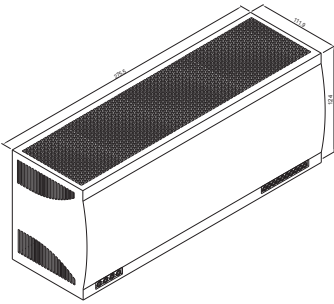





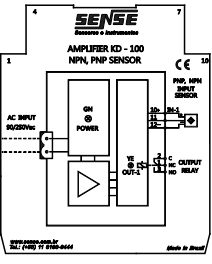
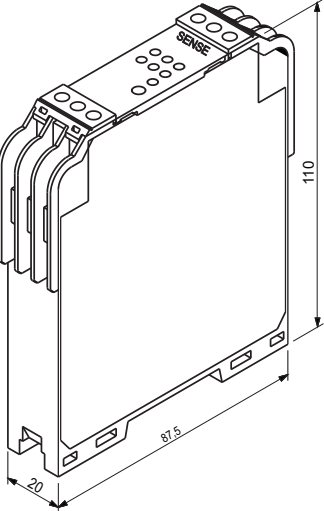

Three Phase Power Supplies

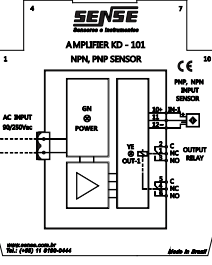
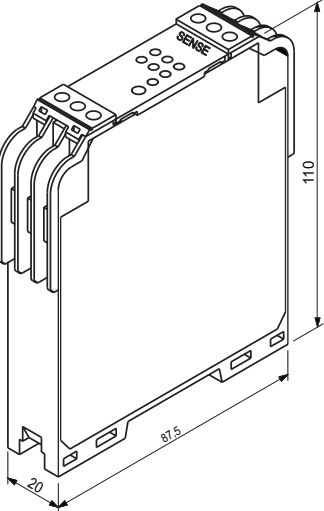
Code	Model	Connection Diagram	Mechanical Design (mm)	Voltage/ Output Current
KFG3-2405/ 340-575 Vca				24 Vdc / 5A
KFG3-2410/ 340-575 Vca				24 Vdc / 10A
KFG3-2420/ 340-575 Vca				24 Vdc / 20A
KFG3-2440/ 340-575 Vca				24 Vdc / 40A

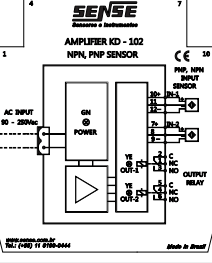
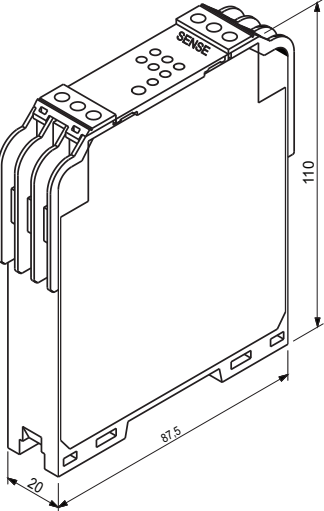
Nota: RDY is a normally open contact used to alarm the DC voltage level.

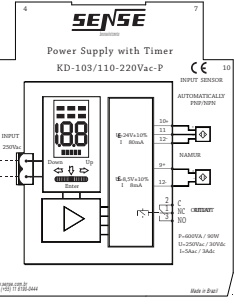
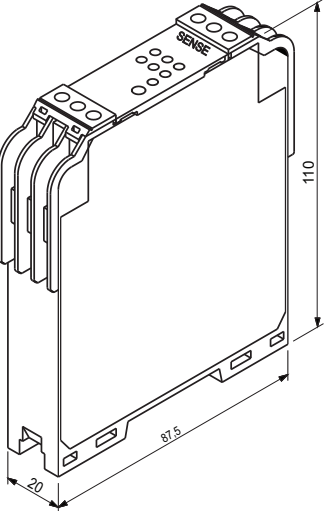

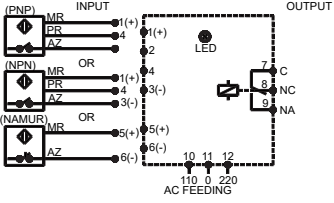
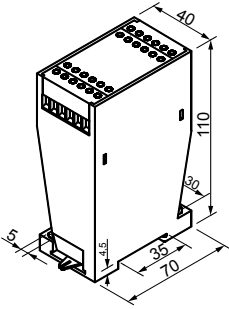

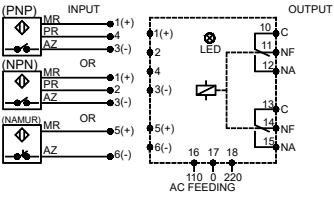
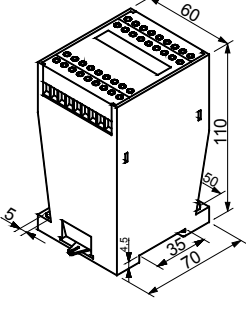



Amplifiers and Controls

Code	Model	Connection Diagram	Mechanical Design (mm)	Application
KD-100N/110-220Vca				Amplifier with relay output for sensors with CC configuration (NPN, PNP)
KD-100P/110-220Vca				
KD-100N/110-220Vca-P (plug-in)				
KD-100P/110-220Vca-P (plug-in)				
KD-101N/110-220Vca				Amplifier with relay output for sensors with CC configuration (NPN, PNP)
KD-101P/110-220Vca				
KD-101N/110-220Vca-P (plug-in)				
KD-101P/110-220Vca-P (plug-in)				
KD-102N/110-220Vca				Amplifier with relay output for sensors with CC configuration (NPN, PNP)
KD-102P/110-220Vca				
KD-102N/110-220Vca-P (plug-in)				
KD-102P/110-220Vca-P (plug-in)				
KD-103P/110-220Vac				Timer amplifier for sensors with CC electrical configuration (PNP or dry contact)
KMV-100/110-220Vca				Amplifier with relay output for sensors with CC configuration (NPN, PNP, NAMUR)
KMV-101/110-220Vca				Amplifier with two relay outputs for sensors with CC configuration (NPN, PNP, NAMUR)

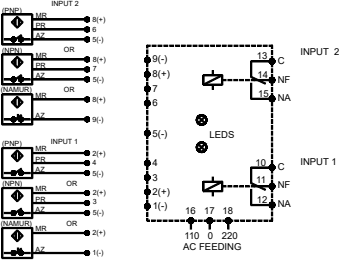
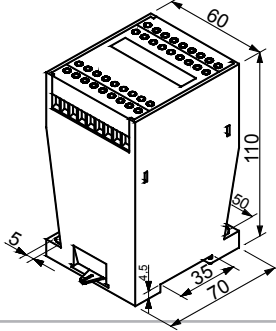

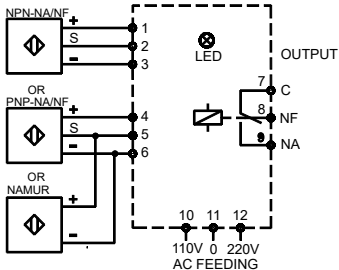
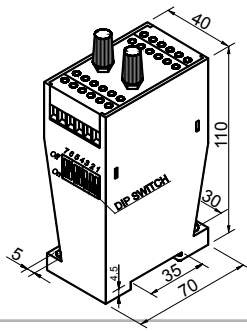
Instruments

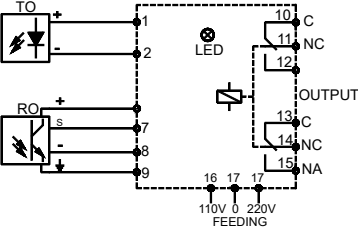
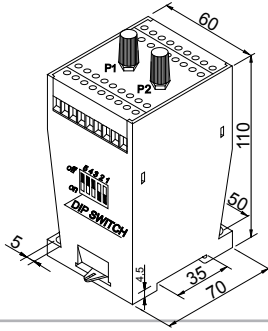

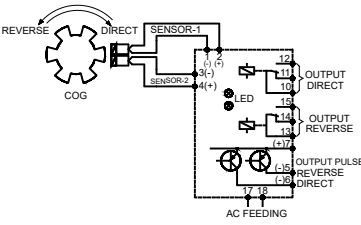
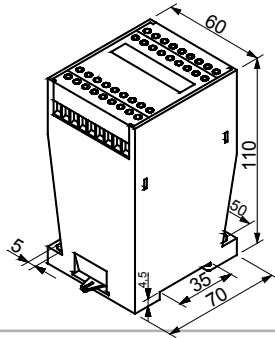



Amplifiers and Controls

Code	Model	Connection Diagram	Mechanical Design (mm)	Voltage/ Output Current
KMV-102/110-220Vca				Amplifier with two inputs and two independent relay outputs for sensors with CC configuration (NPN, PNP, NAMUR)
KMV-103/110-220 VCA				Timer amplifier for sensors with CC electrical configuration (NPN, PNP, NAMUR or dry contact)
KMV-150/110-220 VCA				Timer amplifier for photoelectric sensors that do not have an output stage (TO/RO-8H or TO/RO-12H sensors)
KMV-235/110-220 VCA				Direction of rotation detection using two NAMUR sensors

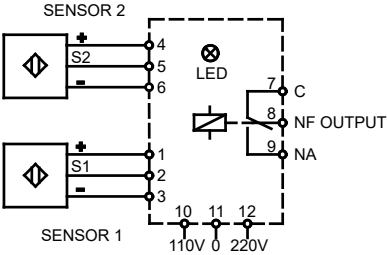
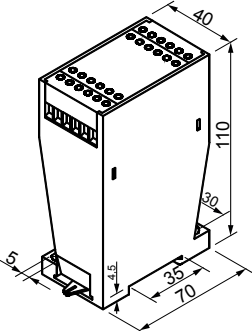

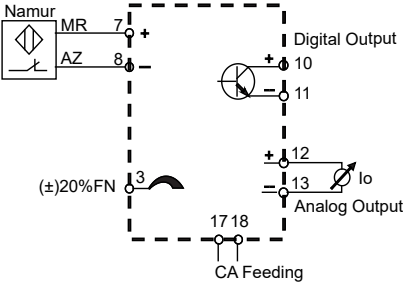
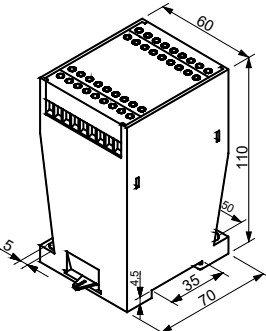
Instruments

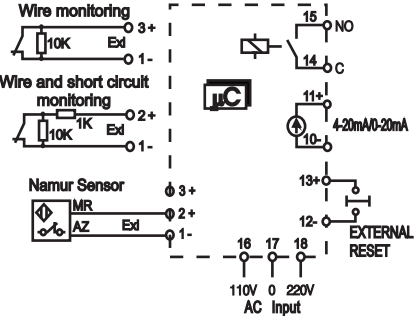
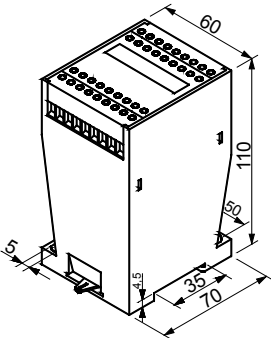
Amplifiers and Controls

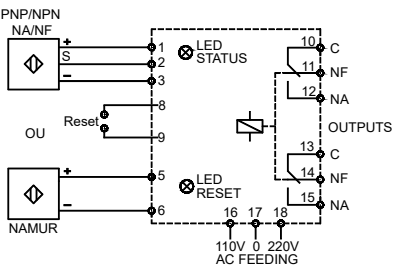
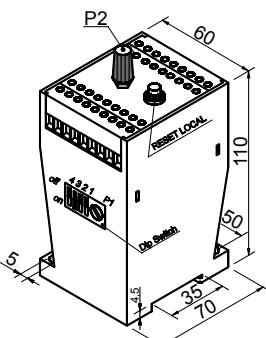
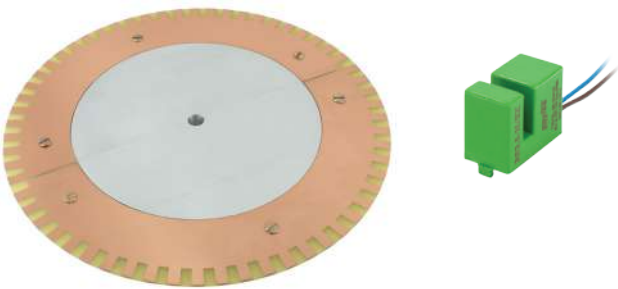
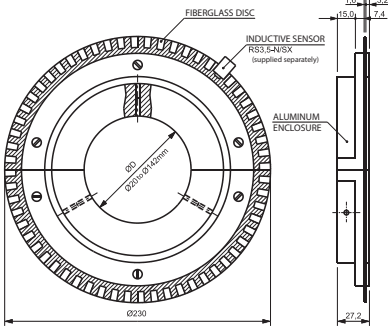
Code	Model	Connection Diagram	Mechanical Design (mm)	Application
KMV-118/ 110-220 Vca				Level control
KMV-228/ 110-220 Vca (output: 4 a 20 mA)				Speed transducer using NAMUR sensor and digital or analog output 4 to 20 mA or 0 to 20 mA
KMV-229/ 110-220 Vca (output: 0 a 20 mA)				
KMV-400NPN/ 110-220 Vca				Monitoring and indication of rotation with NPN or PNP sensor or mechanical contact
KMV-400PNP/ 110-220 Vca				
KMV-333/ 110-220 Vca				Speed monitoring using proximity sensor (NPN, PNP or NAMUR)
Bi-drive wheel RD60-230/FXXX-Bi Sensor RS3,5-N/SX			Speed and rotation monitoring and transduction	

WWW.SENSE.COM.BR



CENTRAL OFFICE - SÃO PAULO

Rua Tuiuti, 1237 - Tatuapé
São Paulo - SP - Cep: 03081-012
Phone: +55 11 2145-0444
sales@sense.com.br

FACTORY - MINAS GERAIS

Av. Joaquim Moreira Carneiro. 600 - Santana
Santa Rita do Sapucaí - MG - Cep: 37540-000
Phone: +55 35 3471-2555